

Advancing the Science of Sealing™

Garlock Metallic Gasket Catalog



Garlock
SEALING TECHNOLOGIES®

an EnPro Industries company

Garlock Metallic Gaskets

Garlock Metallic Gaskets, a division of Garlock Sealing Technologies, manufactures spiral wound, metal clad, solid metal and metal core gaskets at its facility in Houston, Texas. This facility is registered to ISO-9001.

In recent years, Garlock Metallic Gaskets has introduced some of the industry's most innovative production methods and products. For example, the CONTROLLED DENSITY™ process for spiral wound gaskets ensures a high tightness level at a lower bolt stress. The TANDEM SEAL™ combines chemical resistance and fire safety in a single gasket. The Garlock EDGE® gasket seals at lower bolt stress while virtually eliminating the problem of inward buckling. Garlock Metallic Gaskets is also known for excellence in material and product quality as well as its outstanding customer service.

This catalog is provided for customer information and convenience. However, Garlock Metallic Gaskets applications engineers and customer service personnel are also on hand to assist you with your application requirements and technical questions. Please give us a call at 1-888-GARLOCK. We are here to serve you.



CONTROLLED DENSITY™, TANDEM SEAL™, STABL-LOCK™ and G.E.T.™ are trademarks of Garlock Inc.
EDGE®, GRAPHONIC®, FLEXSEAL® and TEPHONIC® are registered trademarks of Garlock Inc.

Contents

Metallic Gasket Styles

Gasket Selection	D-2
Spiral Wound Gaskets	D-3
Performance Metrics	D-4
The Garlock EDGE® Gasket	D-5
HEAT SHIELD™ Gasket	D-6
TANDEM SEAL™ Gasket	D-7
FLEXSEAL® Family	D-8
RW, RWI, SW (For ASME flanges)	D-8
MC, MCR (For boiler manholes)	D-9
HH (For boiler handholes)	D-10
RW-RJ, RWI-RJ (For ring joint flanges)	D-11
LMF (For large male/female flanges)	D-12
LTG (For large tongue and groove flanges)	D-12
STG (For small tongue and groove flanges)	D-12
Exchanger and Vessel Gaskets	D-13
Heat Exchanger Gasket Configurations	D-13
600 Series Metal-Clad Gaskets	D-14
GRAPHONIC® Metallic Gasket	D-16
Garlock Kammprofile Gasket	D-17

Engineering Data

Factors Affecting Gasket Performance	D-18
Material Temperature Limits	D-19
Thickness and Tolerances	D-19
Flange Types	D-20
Recommended Flange Finish	D-21
Maximum Bore	D-22
Gasket Dimensions	D-23
Gasket Factors M and Y	D-32
Torque Tables	D-33
Flange and Bolt Dimensions	D-39
Gasket Installation	D-40
Troubleshooting Leaking Joints	D-41
Ordering Guide	D-42
Application Data Form	D-43

Gasket Selection

Spiral Wound Gaskets

One of the best all-around seals, the spiral wound gasket offers a low-cost solution that has the ability to handle temperature and pressure fluctuations. Multiple plies of metal and filler in the spiral create a barrier that reduces the possibility of leaks.

Other Metal Gaskets

Garlock manufactures a wide variety of double-jacketed, spiral-wound, metal-clad and solid metal gaskets for heat exchanger and coker applications. GRAPHONIC® and Kammprofile gaskets are also available in heat exchanger configurations.

Temperature and Chemical Considerations

Be certain that the gasket you order is as resistant as possible to the media and temperature involved. Check the chemical compatibility of the metal as well as the filler material for the media to be sealed. As a general rule, the metal used in either the spiral winding or double-jacketed gasket should be similar to the flange material.

The compressibility of flexible graphite makes it an excellent filler material for metallic gaskets. Flexible graphite may be used in services with temperatures up to 850°F (450°C), though it should not be used with strong

oxidizers such as nitric or sulfuric acid.

PTFE filler material provides excellent chemical resistance at temperatures below 500°F (260°C). In accordance with ASME B16.20, an inner ring is required when using conventional PTFE filler materials, in order to protect the winding from radial buckling.

See page D-19 for the temperature limits of common metals and filler materials.

Operating Pressure

Operating pressures have a direct effect on the construction and selection of metallic gaskets. Higher pressures raise the potential for gasket blowout, while lower pressure applications require a gasket design that seals under lower bolt loads.

Garlock gaskets suitable for high pressure include:

- Kammprofile gaskets
- Spiral wound gaskets with inner ring
- Solid metal gaskets

Low pressure gaskets include:

- GRAPHONIC® gaskets
- Garlock Kammprofile gaskets
- The Garlock EDGE® gasket

WARNING:

Properties/applications shown throughout this brochure are typical. Your specific application should not be undertaken without independent study and evaluation for suitability. For specific application recommendations consult Garlock. Failure to select the proper sealing products could result in property damage and/or serious personal injury.

Performance data published in this brochure has been developed from field testing, customer field reports and/or in-house testing.

While the utmost care has been used in compiling this brochure, we assume no responsibility for errors. Specifications subject to change without notice. This edition cancels all previous issues. Subject to change without notice.

Spiral Wound Gaskets

Manufactured in Accordance with ASME B16.20

Spiral wound gaskets—made with an alternating combination of formed metal wire and soft filler materials—form a very effective seal when compressed between two flanges. A v-shaped crown centered in the metal strip acts as a spring, giving gaskets greater resiliency under varying conditions. Filler and wire material can be changed to accommodate different chemical compatibility requirements. Fire safety can be assured by choosing flexible graphite as the filler material. If the load available to compress a gasket is limited, gasket construction and dimensions can be altered to provide an effective seal.

A spiral wound gasket may include a centering ring, an inner ring or both. The outer centering ring centers the gasket within the flange and acts as a compression limiter, while the inner ring provides additional radial strength. The inner ring also reduces flange erosion and protects the sealing element.

Resiliency and strength make spiral wound gaskets an ideal choice under a variety of conditions and applications. Widely used throughout refineries and chemical processing plants, spiral wound gaskets are also effective

for power generation, pulp and paper, aerospace, and a variety of valve and specialty applications.

As set forth in ASME B16.20, all PTFE filled spiral wound gaskets will be supplied with inner rings. In addition, the following higher pressure class spirals will be supplied with inner rings for all filler material:

- NPS 24 and larger 900#
- NPS 12 and larger 1500#
- NPS 4 and larger 2500#

Starting in May 2008, the metricated edition of this standard recommends the use of inner rings for all graphite filled spiral wound gaskets. However, these gaskets may be specified without inner rings by the purchaser. Both styles will still be stamped ASME B16.20 compliant on the outer guide ring.

Gasket Identification Markings Required by ASME B16.20

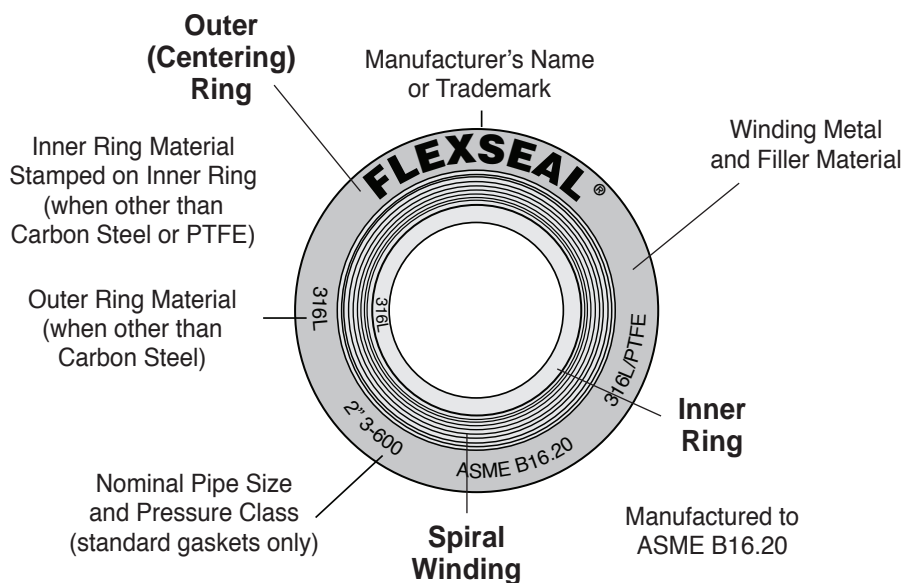

Performance Metrics

Controlled Density™ Process

- Garlock manufacturing process ensures optimum filler density across the gasket winding to achieve consistent compression and superior sealability
- High tightness level achieved with minimal compressive load, for longer-lasting seal
- All SW gaskets manufactured in accordance with the guidelines set forth in the ASME B16.20 specifications



ROTT Test and Results

ROTT Test

- **Purpose:** Determine room temperature sealing capabilities, by measuring the sealability of a gasket at incremental gasket stress values
- **Sample used:** Two 304 SS and flexible graphite-filled 4" Class 150 ASME B16.20 spiral wound gaskets
- **Procedure:** The leak rate is measured during the loading and unloading cycles, and a tightness curve is generated.*

Test Results

- When compared with other spiral wound gaskets, the Garlock metallic gasket was able to achieve equivalent tightness at a lower load in all tightness parameter values.
- During stress cycling, the performance of the Garlock metallic gasket gaskets was excellent, compared with other spiral wound gaskets.

Gasket Style and Material	Gasket Factor "M"	Gasket Factor "Y" (psi)
Traditional spiral wound gasket – 304 SS and flexible graphite	3.00	10,000
Garlock spiral wound gasket	3.00	7,500

Gasket Material	Gasket Constant Gb (psi)	Gasket Constant 'a'	Gasket Constant Gs (psi)	Stress Req'd for Tightness of 100 (psi)	Stress Req'd for Tightness of 1000 (psi)	Stress Req'd for Tightness of 10,000 (psi)
Garlock flexible graphite-filled spiral wound gasket (ASME B16.20)	627	0.35	6.22	3,140	7,040	11,430
Flexible graphite spiral wound gasket	2,300	0.237	13	6,851	11,823	20,405
PTFE-filled spiral wound gasket	4,500	0.14	70	8,575	11,836	16,339
Foil-reinforced flexible graphite sheet	816	0.377	0.066	4,631	11,033	26,284
Garlock GRAPHONIC® gasket	315	0.36	1.857	1,653	3,787	8,676
"Low stress" spiral wound type gasket, flexible graphite filled	598	0.385	0.03	3,520	8,540	14,570
Garlock Kammprofile gasket	368	0.4	0.28	2,324	5,838	14,664

Comparison of Seating Requirements

* Gb = stress at which seal is initiated; "a" = the slope of the log/log tightness curve; Gs = intersection of the unload curve with the vertical axis (Tp1)

Note: For a 5" OD gasket at 800 psig, Tp100 = 102ml/min. leakage, Tp1,000 = 1.02ml/min. leakage, Tp10,000 = 0.01 ml/min. leakage.

The Garlock EDGE®

Benefits

Requires lower seating stress

- Seals at lower stress than conventional gaskets without an inner ring
- Eliminates flange damage caused by overtightening
- Relief ports allow tighter seal at lower loads

Eliminates radial buckling

- STABL-LOCK™ inner wrap construction prevents sealing element from flowing into and contaminating process stream

Tightest seal

- Modified guide ring ensures contact centered on raised face flange surfaces*

Multiple applications

- Available in a dual flange (DF) design to accommodate both 150 and 300 lb flanges—reduces inventory costs
- Select from a wide variety of metallic and filler materials with a full range of temperature capabilities**
- Also available in HEAT SHIELD™ configuration for high temp services above 850°F.

Seals with lower bolt loads

- Relief tab design provides solid seating of centering ring face
- Withstands bolt load loss caused by thermal cycling
- Inner wrap construction eliminates radial buckling
- Prevents catastrophic failure and potential damage to downstream equipment due to wire unraveling

* Contact Garlock Engineering when using the EDGE® gasket on lap joint flanges with substandard backing rings.

** See chart on page D-19.

Compare

Standard spiral wound gasket shows excessive inward buckling

The patented Garlock EDGE® spiral wound gasket is designed to reduce inward buckling

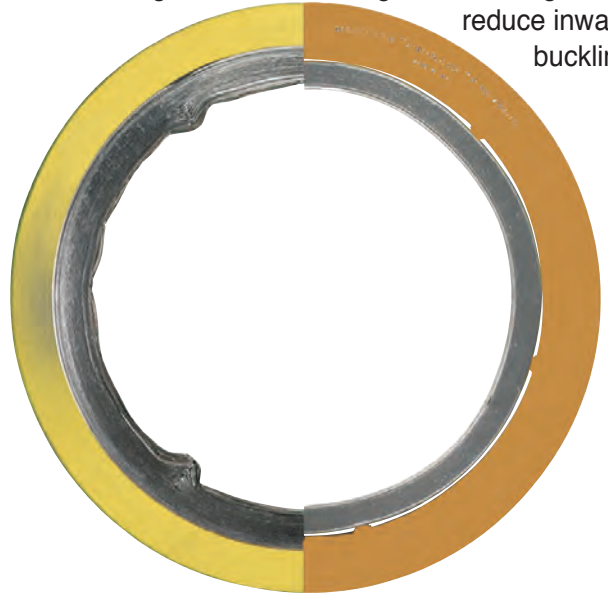

Gasket Style and Material	"M"	"Y" (psi)	Gb (psi)	"a"	Gs (psi)
Garlock EDGE® with 304 stainless and flexible graphite filler	2.00	5,000	793	0.4	0.31

Dual Flange (DF) Design

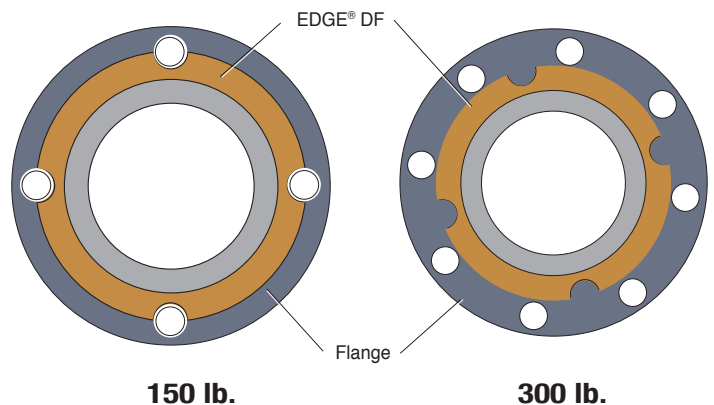

HEAT SHIELD™ Gasket

Benefits

Outstanding fire resistance

- Combination of graphite filler and mica layers give superior fire safety

Ideal for oxidizing environments

- Layers of pure mica protect graphite filler and resist oxidation
- Good choice for plant steam drums, hydrocarbon catcrackers, hydrogen units, and exhaust manifolds

Construction

- Heat-resistant graphite filler
- Heat- and oxidation-resistant pure mica filler
- Spiral-wound wires, available in most commercially available metals
- Rings of any standard metal, including INCONEL* X750

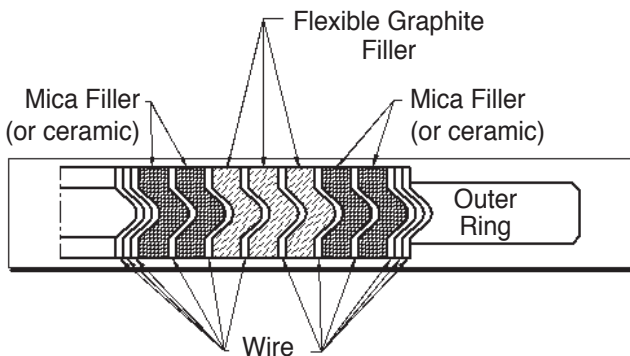

Also available in Kamprofile and EDGE® design

* INCONEL is a registered trademark of Inco Alloys International, Inc.

Specifications

Temperature, max.: 1250°F (677°C)
 Flange class: 150 to 600 lb.
 Pipe diameters: 2" to 24"; specials available

Gasket Style and Material	Gasket Factor "M"	Gasket Factor "Y" (psi)
Traditional spiral wound gasket—304 SS and flexible graphite	3.00	10,000
Garlock spiral wound gasket	3.00	7,500

WARNING:

Properties/applications shown throughout this brochure are typical. Your specific application should not be undertaken without independent study and evaluation for suitability. For specific application recommendations consult Garlock. Failure to select the proper sealing products could result in property damage and/or serious personal injury.

Performance data published in this brochure has been developed from field testing, customer field reports and/or in-house testing.

While the utmost care has been used in compiling this brochure, we assume no responsibility for errors. Specifications subject to change without notice. This edition cancels all previous issues. Subject to change without notice.

TANDEM SEAL™*

Benefits

Chemical-resistant and fire-safe

- PTFE envelope withstands aggressive chemicals and corrosive media
- Fire-safe—passed independent fire tests
- Two sealing elements significantly reduce corrosion and bacterial contamination of flanges
- Seals to the ID of the pipe bore
- Specify pipe schedule when ordering

Seal Comparison

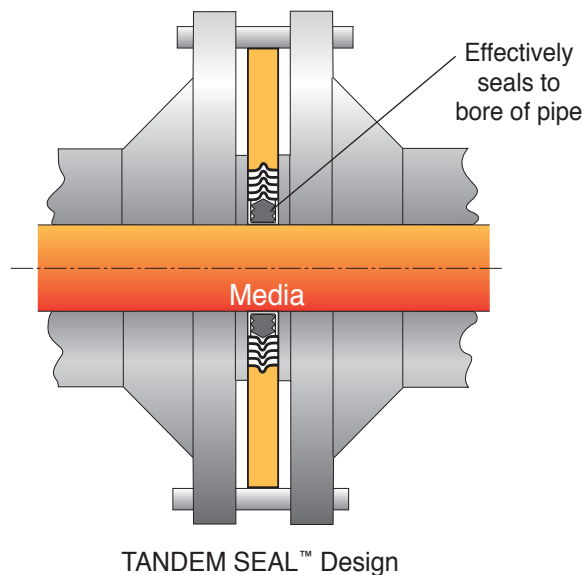
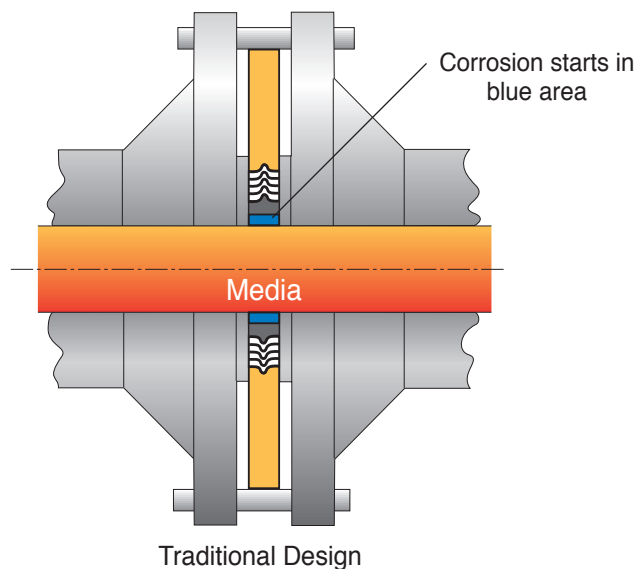

Standard Construction

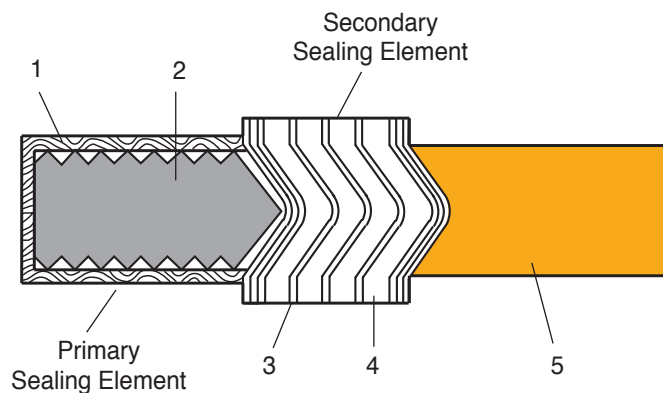

1. PTFE envelope
2. Profiled inner ring
3. Metal windings
4. Filler material
5. Outer guide ring

* Patent No. 5511797

FLEXSEAL® RW, RWI and SW Gaskets

Advantages

- Durable; easy installation and removal
- Seals pressures to flange ratings, in accordance with ASME B16.5
- Suitable for temperatures from cryogenic to 2,000°F (1,093°C)*
- Guide ring simplifies centering of sealing element on the flange face
- Designed solutions accommodate a variety of conditions by combining various metals and filler materials

Style RW

- General purpose gasket suitable for flat face and raised face flanges up to Class 2500**
- Centering ring accurately locates the gasket on the flange face, provides additional radial strength, and acts as a compression limiter
- Spiral winding (sealing element) consists of pre-formed metal and soft filler material

Style RWI

- Suitable for flat face and raised face flanges up to Class 2500**
- Recommended for higher pressure applications, for use with PTFE fillers, and when mandated by ASME B16.20 as follows: NPS 24 and larger in Class 900, NPS 12 and larger in Class 1500, and NPS 4 and larger in Class 2500.
- Inner ring acts as compression limiter and protects sealing elements from process media attack

Style SW

- Suitable for tongue and groove, male-female, or groove-to-flat face flanges†
- Spiral winding only, containing preformed metal and soft filler material
- Also available with inner rings—Style SWI

* Consult Garlock Engineering for material recommendations above 850°F (450°C)

** Depending on gasket size, an inner ring is recommended for applications above Class 600, due to the high available bolt load. See also Note 1, page D-22.

† This design does not have a compression limiter.

Ordering Information

RW/RWI

When ordering specify:

- Nominal pipe size or specific gasket dimensions
- Winding and filler materials
- Centering and/or inner compression ring material
- Pressure rating

SW

When ordering, specify:

- O.D. and I.D. dimensions (and tolerance, if other than standard—see page D-19)
- Thickness of gasket
- Winding and filler material
- Inner ring material, if required (Style SWI)
- Pressure rating

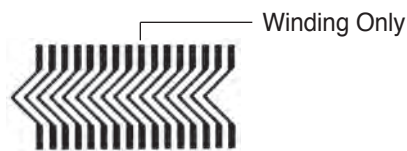
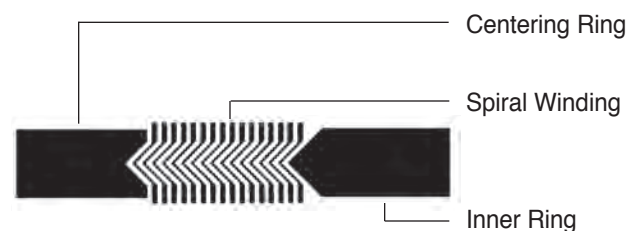
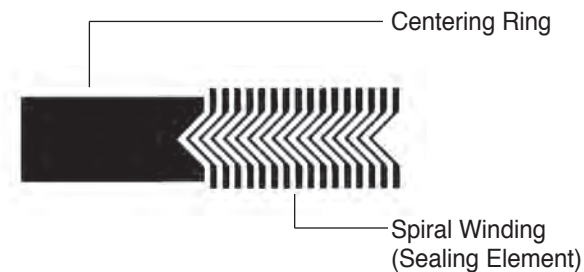

Note: For M & Y factors, see page D-33.
For ROTT Test results, see page D-4.

FLEXSEAL® MC and MCR Gaskets

For Manhole Cover Assemblies

MC Gasket (manhole cover)

- Spiral winding only, containing preformed metal and soft filler material

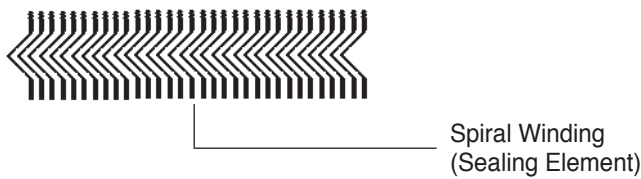

MCR Gasket (manhole cover with centering ring)

- Centering ring accurately locates the gasket on the flange face, provides additional radial strength, and acts as a compression limiter
- Spiral winding (sealing element) consists of preformed metal and soft filler material



Ordering Information

When ordering, specify:

- Make and model of boiler and/or equipment if available (See chart page D-10)
- Gasket style and configuration
- Dimensions of gasket (thickness, flange seating width, and shape)
- Maximum operating pressure and temperature
- Type of metal and filler materials

WARNING:

Properties/applications shown throughout this brochure are typical. Your specific application should not be undertaken without independent study and evaluation for suitability. For specific application recommendations consult Garlock. Failure to select the proper sealing products could result in property damage and/or serious personal injury.

MC and MCR Configurations

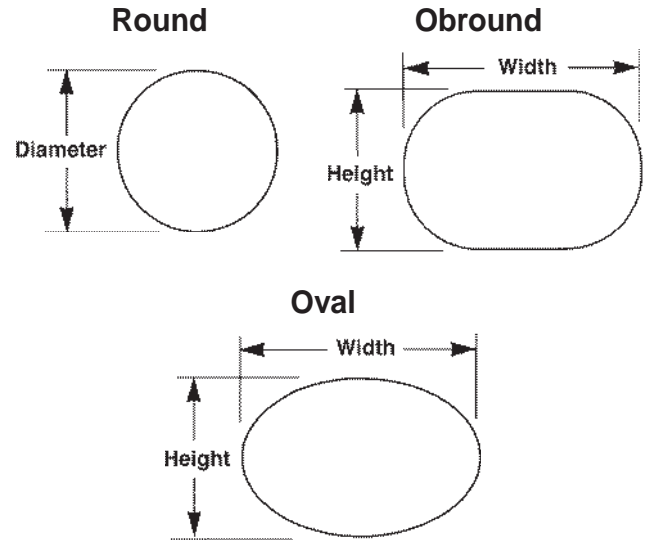

Style	Nominal I.D. Dimensions (Inches)	Thickness (Inches)	Flange Width (Inches)
MC Oval	11 x 15	0.175	3/4
MC Oval	11 x 15	0.175	15/16
MC Oval	11 x 15	0.175	1-1/4
MC Oval	12 x 16	0.250	15/16
MCR Oval	12 x 16	0.250	13/16
MC Oval	12 x 16	0.175	3/4
MC Oval	12 x 16	0.175	15/16
MC Oval	12 x 16	0.175	1-1/4
MC Oval	12 x 16	0.250	1-1/4
MC Round	16-1/16	0.175	3/4

Dimensions of MC and MCR Gaskets

Notes:

1. For pitted and rough flange surfaces, specify a gasket thickness of 0.250".
2. Orders for special cover assemblies should be accompanied by a dimensional drawing showing the minimum width of seating surfaces and other essential dimensions.
3. Style MC oval and obround gaskets are available in 0.175" and 0.250" thickness and in varying widths as shown above.
4. Orders for non-standard gaskets should also include a sketch or drawing of the cover assembly with all dimensions shown.

Performance data published in this brochure has been developed from field testing, customer field reports and/or in-house testing.

While the utmost care has been used in compiling this brochure, we assume no responsibility for errors. Specifications subject to change without notice. This edition cancels all previous issues. Subject to change without notice.

FLEXSEAL® HH Gaskets

For Boiler Handhole and Tubecap Assemblies

- Fits most standard boilers (specify maximum operating pressure when ordering)
- Available in thicknesses of 0.125" (special), 0.175" (standard) and 0.250" (special—for pitted surfaces)

Style HH Configurations

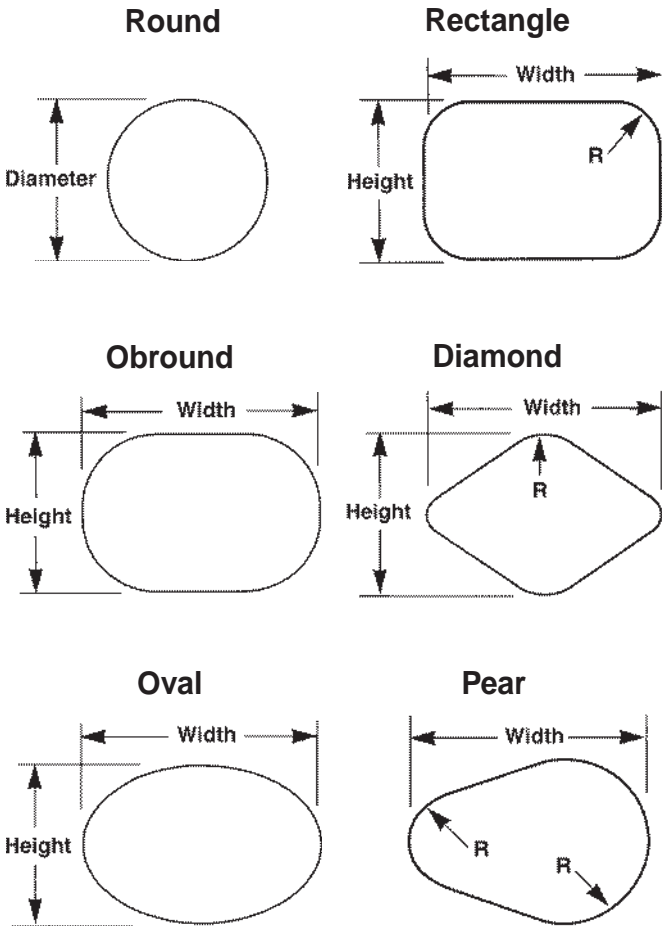

WARNING:

Properties/applications shown throughout this brochure are typical. Your specific application should not be undertaken without independent study and evaluation for suitability. For specific application recommendations consult Garlock. Failure to select the proper sealing products could result in property damage and/or serious personal injury.

Performance data published in this brochure has been developed from field testing, customer field reports and/or in-house testing.

While the utmost care has been used in compiling this brochure, we assume no responsibility for errors. Specifications subject to change without notice. This edition cancels all previous issues. Subject to change without notice.

Boiler Gasket Dimensions

Manufacturer and Model No.	Shape	Nominal I.D. Dimensions (Inches)	Flange Width (Inches)
Babcock and Wilcox #40 (207)	Diamond	3-3/8 x 3-3/4	3/16
#48 (208)	Oval	3-13/16 x 4-3/4	7/32
#24 (211)	Oval	4-1/2 x 5-1/2	7/32
#47	Round	2-1/32	3/16
#70	Round	3-9/32	3/16
#28 (212)	Rectangle	4-13/16 x 5	7/32
Badenhausen (See Riley Stoker)			
Cleaver-Brooks	Obround	3-9/32 x 4-17/32	3/8
Combustion Engr. 29N-L839	Diamond	3-3/8 x 4-1/4	1/4
4N-L740	Round	3-1/8	1/4
5N-L902	Round	3-5/8	1/4
Foster Wheeler 2 3/4 (1003)	Obround	2-25/32 x 3-13/32	7/32
3 15/16 (1005)	Oval	4-3/16 x 5-3/16	5/16
Heine	Round	3-5/8	3/8
Keeler	Obround	3 x 4	3/8
Oilfield	Oval	3 x 4	3/8
	Oval	3-1/2 x 4-1/2	3/8
Riley Stoker W-C2	Obround	3-23/32 x 5-23/32	11/32
Springfield	Oval	3-17/32 x 4-17/32	5/16
Union	Oval	3 x 4	3/8
	Pear	4-1/4 x 5-1/4	3/8
Vogt	Oval	4-1/4 x 5-1/8	7/32 (new)
Wickes			
D2300	Pear	4-1/8 x 5-1/8	9/32
D2301	Oval	3 x 4	5/16
	Oval	3-1/2 x 4-1/2	5/16

Ordering Information

When ordering, specify:

- Make and model of boiler and/or equipment, if available
- Gasket style and configuration
- Dimensions of gasket (thickness, flange seating width, and shape)
- Maximum operating pressure and temperature
- Type of metal and filler materials

FLEXSEAL® RW-RJ, RWI-RJ Gaskets

For Replacement of Ring Joint Gaskets

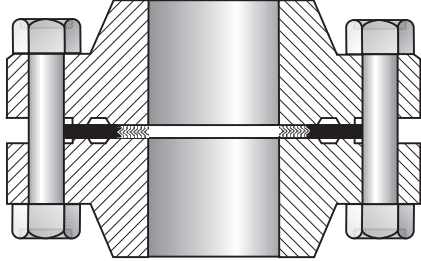

- Ideal replacement for solid metal oval or octagonal API ring joint gaskets (RTJ)
- Saves cost of flange replacement when gasket groove is badly worn
- Fast and easy installation—requires only a 3/16" flange separation (ring joint gasket may require as much as 3/4")
- Wide variety of metal and filler materials have a full range of temperature and pressure capabilities
- RW-RJ gaskets not stocked, but can be special-ordered; RWI-RJ gaskets available on request.

Nominal Pipe Size (Inches)	150 psi			300 psi			400 psi		
	Gasket I.D.	Gasket O.D.	Ring O.D.	Gasket I.D.	Gasket O.D.	Ring O.D.	Gasket I.D.	Gasket O.D.	Ring O.D.
1/2	—	—	—	9/16	1-1/16	2-1/8	9/16	1-1/16	2-1/8
3/4	—	—	—	13/16	1-5/16	2-5/8	13/16	1-5/16	2-5/8
1	1-1/8*	1-5/8*	2-5/8*	1-1/16	1-5/8	2-7/8	1-1/16	1-5/8	2-7/8
1-1/4	1-3/8*	1-7/8*	3*	1-5/16	2	3-1/4	1-5/16	2	3-1/4
1-1/2	1-5/8*	2-1/4*	3-3/8*	1-9/16	2-3/8	3-3/4	1-9/16	2-3/8	3-3/4
2	2-1/8*	2-7/8*	4-1/8*	2-1/8	2-3/4	4-3/8	2-1/8	2-3/4	4-3/8
2-1/2	2-3/4*	3-5/16*	4-7/8*	2-3/4	3-5/16	5-1/8	2-3/4	3-5/16	5-1/8
3	3-5/16*	3-15/16*	5-3/8*	3-5/16	3-15/16	5-7/8	3-5/16	3-15/16	5-7/8
4	4-5/16*	5-3/16*	6-7/8*	4-5/16	5-3/16	7-1/8	4-5/16	5-3/16	7
5	5-5/16*	6-3/16*	7-3/4*	5-5/16	6-7/16	8-1/2	5-5/16	6-7/16	8-3/8
6	6-5/16*	7-3/16*	8-3/4*	6-7/16	7-5/8	9-7/8	6-7/16	7-5/8	9-3/4
8	8-1/4*	9-3/16*	11*	8-1/4	9-15/16	12-1/8	8-1/4	9-15/16	12
10	10-5/16*	11-7/16*	13-3/8*	10-5/16	12	14-1/4	10-5/16	12	14-1/8
12	12-3/16*	13-9/16*	16-1/8*	12-7/8†	14-1/4†	16-5/8†	12-7/8†	14-1/4†	16-1/2†
14	13-7/16*	14-15/16*	17-3/4*	14-1/4†	15-3/4†	19-1/8†	14-1/4†	15-3/4†	19†
16	15-5/16*	16-15/16*	20-1/4*	16-1/4†	17-3/4†	21-1/4†	16-1/4†	17-3/4†	21-1/8†
18	17-1/4*	19*	21-5/8*	18-1/4†	20-1/4†	23-1/2†	18-1/4†	20-1/4†	23-3/8†
20	19-1/8*	21-1/8*	23-7/8*	20-1/4†	22-3/16†	25-3/4†	20-1/4†	22-3/16†	25-1/2†
24	23*	25-1/4*	28-1/4*	24-1/4†	26-5/16†	30-1/2†	24-1/4†	26-5/16†	30-1/4†

Nominal Pipe Size (Inches)	600 psi			900 psi			1500 psi		
	Gasket I.D.	Gasket O.D.	Ring O.D.	Gasket I.D.	Gasket O.D.	Ring O.D.	Gasket I.D.	Gasket O.D.	Ring O.D.
1/2	9/16	1-1/16	2-1/8	9/16*	1-1/16*	2-1/2*	9/16*	1-1/16*	2-1/2*
3/4	13/16	1-5/16	2-5/8	13/16*	1-3/8*	2-3/4*	13/16*	1-3/8*	2-3/4*
1	1-1/16	1-5/8	2-7/8	1-1/16*	1-5/8*	3-1/8*	1-1/16*	1-5/8*	3-1/8*
1-1/4	1-5/16	2	3-1/4	1-5/16*	2*	3-1/2*	1-5/16*	2*	3-1/2*
1-1/2	1-9/16	2-3/8	3-3/4	1-9/16*	2-3/8*	3-7/8*	1-9/16*	2-3/8*	3-7/8*
2	2-1/8	2-3/4	4-3/8	2-1/4*	3-1/4*	5-5/8*	2-1/4*	3-1/4*	5-5/8*
2-1/2	2-3/4	3-5/16	5-1/8	2-9/16*	3-5/8*	6-1/2*	2-9/16*	3-5/8*	6-1/2*
3	3-5/16	3-15/16	5-7/8	3-3/16*	4-3/16*	6-5/8*	3-3/16*	4-11/16*	6-7/8*
4	4-5/16	5-3/16	7-5/8	4-1/16*	5-3/16*	8-1/8*	4-1/16*	5-11/16*	8-1/4*
5	5-5/16	6-7/16	9-1/2	5-5/16	6-7/16	9-3/4	5-1/16*	6-15/16*	10*
6	6-7/16	7-5/8	10-1/2	6-5/16	7-5/8	11-3/8	6*	7-9/16*	11-1/8*
8	8-1/4	9-15/16	12-5/8	8-1/4	9-15/16	14-1/8	7-7/8*	9-3/4*	13-7/8*
10	10-5/16	12	15-3/4	10-5/16	12	17-1/8	9-13/16*	11-7/8*	17-1/8*
12	12-7/8†	14-1/4†	18†	12-7/8	14-1/4	19-5/8	11-15/16*	13-13/16*	20-1/2*
14	14-1/4†	15-3/4†	19-3/8†	13-13/16	15-9/16	20-1/2	13-7/16	15-3/16	22-3/4
16	16-1/4†	17-3/4†	22-1/4†	15-9/16	17-9/16	22-5/8	15	17	25-1/4
18	18-1/4†	20-1/4†	23-3/8†	17-11/16	19-15/16	25-1/8	17-1/4	19-1/2	27-3/4
20	20-1/4†	22-3/16†	26-7/8†	19-11/16	21-15/16	27-1/2	19-3/16	21-7/16	29-3/4
24	24-1/4†	26-5/16†	31-1/8†	23-3/16	25-15/16	33	23	25-1/2	35-1/2

Dimensions for weld neck type flanges having a pipe bore equal to that of schedule 40 pipe and heavier, but not for slip-on flanges; except:

† Both charts: suitable for slip-on and weld neck type flanges

* Top chart: for weld neck type flanges having a pipe bore equal to that of schedule 40 pipe. Not for slip-on flanges.

* Bottom chart: for schedule 80 pipe and heavier.

FLEXSEAL® LMF, LTG and STG Gaskets

For Male-Female, Tongue and Groove Flanges

- Spiral winding of preformed metal and soft filler material—for use where no space is provided for a compression guide ring
- Inner diameter of windings is reinforced with several plies of metal without filler to give greater stability
- Style LMF — large male-female flanges
Style LTG — large tongue and groove flanges
Style STG — small tongue and groove flanges

Applications

- Valves
- Pumps
- Flanges
- Heat exchangers
- Vessels

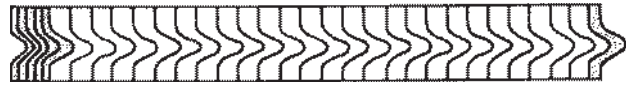

Cross Sectional View of Winding

Ordering Information

When ordering, specify:

- Nominal pipe size
- Pressure rating
- Winding materials (304 SS is standard, filler material must be specified)
- Thickness of winding (0.125" is standard)

Style LMF Gasket Dimensions

Nominal Pipe Size (Inches)	150 - 1500 psi		Nominal Pipe Size (Inches)	2500 psi	
	I.D. (Inches)	O.D. (Inches)		I.D. (Inches)	O.D. (Inches)
1/4	1/2	1	1/2	13/16	1-3/8
1/2	1	1-3/8	3/4	1-1/16	1-11/16
3/4	1-5/16	1-11/16	1	1-1/4	2
1	1-1/2	2	1-1/4	1-5/8	2-1/2
1-1/4	1-7/8	2-1/2	1-1/2	1-7/8	2-7/8
1-1/2	2-1/8	2-7/8	2	2-3/8	3-5/8
2	2-7/8	3-5/8	2-1/2	3	4-1/8
2-1/2	3-3/8	4-1/8	3	3-3/4	5
3	4-1/4	5	3-1/2	—	—
3-1/2	4-3/4	5-1/2	4	4-3/4	6-3/16
4	5-3/16	6-3/16	5	5-3/4	7-5/16
4-1/2	5-11/16	6-3/4	6	6-3/4	8-1/2
5	6-5/16	7-5/16	8	8-3/4	10-5/8
6	7-1/2	8-1/2	10	10-3/4	12-3/4
8	9-3/8	10-5/8	12	13	15
10	11-1/4	12-3/4			
12	13-1/2	15			
14	14-3/4	16-1/4			
16	17	18-1/2			
18	19-1/4	21			
20	21	23			
24	25-1/4	27-1/4			

Style LTG Dimensions

Nominal Pipe Size (Inches)	150 - 2500 psi	
	I.D. (Inches)	O.D. (Inches)
1/2	1	1-3/8
3/4	1-5/16	1-11/16
1	1-1/2	2
1-1/4	1-7/8	2-1/2
1-1/2	2-1/8	2-7/8
2	2-7/8	3-5/8
2-1/2	3-3/8	4-1/8
3	4-1/4	5
3-1/2	4-3/4	5-1/2
4	5-3/16	6-3/16
5	6-5/16	7-5/16
6	7-1/2	8-1/2
8	9-3/8	10-5/8
10	11-1/4	12-3/4
12	13-1/2	15
14	14-3/4	16-1/4
16	17	18-1/2
18	19-1/4	21
20	21	23
24	25-1/4	27-1/4

Style STG Dimensions

Nominal Pipe Size (Inches)	150 - 2500 psi	
	I.D. (Inches)	O.D. (Inches)
1/2	1	1-3/8
3/4	1-5/16	1-11/16
1	1-1/2	1-7/8
1-1/4	1-7/8	2-1/4
1-1/2	2-1/8	2-1/2
2	2-7/8	3-1/4
2-1/2	3-3/8	3-3/4
3	4-1/4	4-5/8
3-1/2	4-3/4	5-1/8
4	5-3/16	5-11/16
5	6-5/16	6-13/16
6	7-1/2	8
8	9-3/8	10
10	11-1/4	12
12	13-1/2	14-1/4
14	14-3/4	15-1/2
16	16-3/4	17-5/8
18	19-1/4	20-1/8
20	21	22
24	25-1/4	26-1/4

WARNING:

Properties/applications shown throughout this brochure are typical. Your specific application should not be undertaken without independent study and evaluation for suitability. For specific application recommendations consult Garlock. Failure to select the proper sealing products could result in property damage and/or serious personal injury.

Performance data published in this brochure has been developed from field testing, customer field reports and/or in-house testing.

While the utmost care has been used in compiling this brochure, we assume no responsibility for errors. Specifications subject to change without notice. This edition cancels all previous issues. Subject to change without notice.

Exchanger and Vessel Gaskets

Garlock manufactures a wide variety of solid metal, metal clad, and metal core gaskets. Among the most requested styles are double-jacketed gaskets, Kamm-profile, corrugated gaskets, and solid metal gaskets, all available in a choice of metals and filler materials.

Custom configurations of heat exchanger gaskets are also available. Spiral windings can be designed with or without partitions welded to the winding, or inner and outer rings with welded partitions. Contact Garlock for all of your heat exchanger and vessel gasket needs.

Garlock Heat Exchanger Gasket Configurations

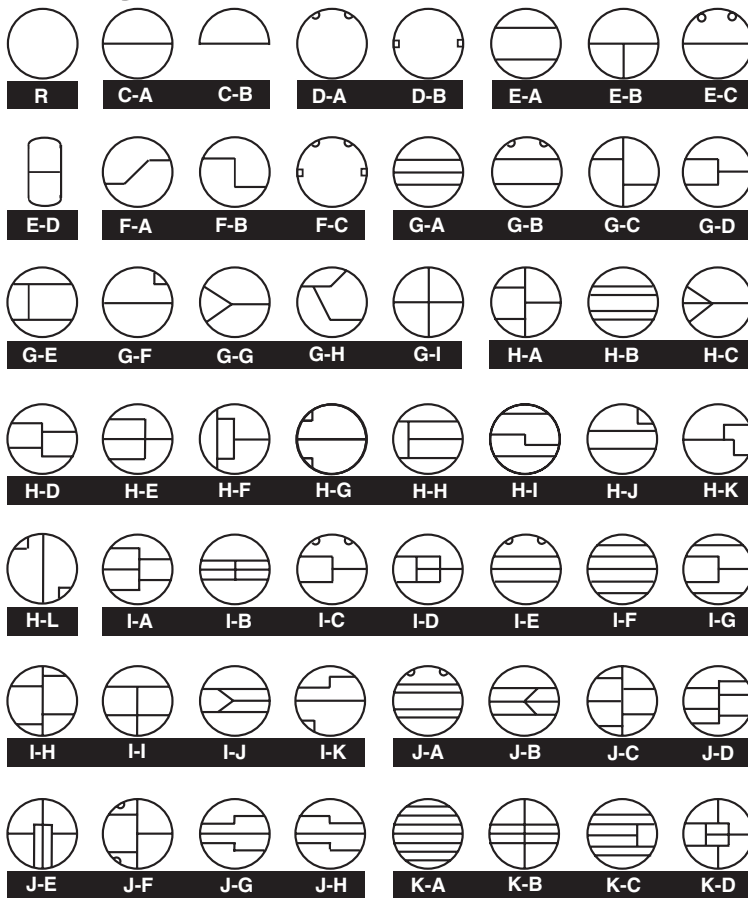

Tolerances

Gasket Outside Diameter	Inside Diameter Tolerance	Outside Diameter Tolerance
Up to 36"	+1/16" / -0	+0 / -1/16"
36" and above	+1/8" / -0	+0 / -1/8"

Thickness: $\pm 1/32"$
Rib Width: $\pm 1/64"$

Radii: $\pm 1/16"$
Rib Location: $\pm 1/16"$

Gasket Widths

Gasket Diameter	Minimum Width (Gasket and Ribs)	Maximum Width
Up to 12"	3/16"	*
Over 12"	1/4"	*

* **Note:** There is no maximum width for heat exchanger gaskets.

Series 600 Metal-Clad Gaskets

Gasket Styles

Style 600—Corrugated Solid Metal

A plain, all-metal corrugated gasket for use in low pressure applications that require a thin line contact because of space or weight limitations. Corrugated gaskets are a versatile sealing element where the available bolt loads are low.



Style 606—Solid Metal with Flexible Graphite Covering

A solid metal gasket covered with a layer of flexible graphite. This covering layer seals at a low load and fills voids and imperfections in the flange.

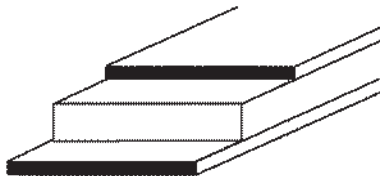

Style 620—Single-Jacketed

Generally used where the radial dimensions of the equipment sealing surfaces only allow space for a narrow width seal. Single-jacketed gaskets are constructed as shown. The metal jacket reinforces the soft sealing material.

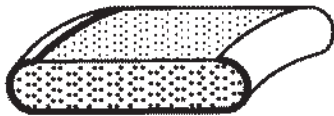

Style 623—Double-Jacketed

The double-jacketed gasket has good compressibility and resilience and is the most popular metal-clad gasket manufactured.

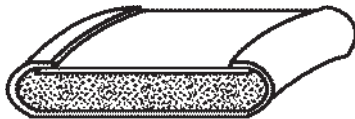

Style 624—Single-Jacketed Overlap

Construction of this gasket offers more filler protection than the standard single-jacketed design. Although constructed like a single-jacketed gasket, it has the added benefit of totally encasing the filler material.

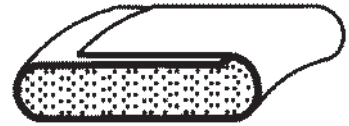

Style 626—Double-Jacketed Corrugated

Concentric corrugated sealing element totally encapsulates the soft filler material. The corrugations give improved resilience in applications where thermocycling is a problem.

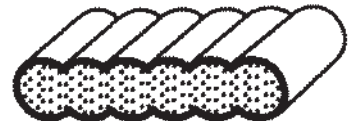

Style 627—Double Shell

The double shell on this gasket allows greater hoop strength and rigidity with the addition of a completely overlapping inner seal. This gasket will withstand higher compressive loads common in high pressure applications.

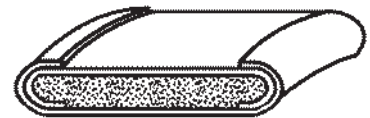

Style 629—Double-Jacketed Corrugated with Corrugated Metal Filler

The metal filler in Style 629 has greater resilience to problems resulting from thermocycling. The temperature limits of this gasket are governed only by the metal selected.



Series 600 Gasket Styles

Style 631—Two-Piece French-Type

Garlock Style 631 is ideal for narrow circular applications that require a positive unbroken metal gasket line across the full width of the flange. The filler is exposed on the OD. This gasket is also available in one, two, and three-piece constructions.



Style 635—Selected Metal and CERAFELT®*

This gasket is designed to be used in lightweight flanges. The thick compressible layer of CERAFELT® is shielded on the ID with a metallic barrier. Style 635 is commonly used in applications with very hot gases and low pressures.

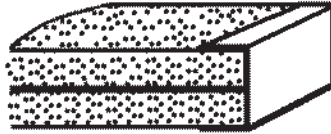

Style 640—Solid Metal

This gasket offers extremely tight sealing, high mechanical strength, and good resistance to temperature, corrosion and pressure. Bolting stress and flange surface finish are key to the performance of this design.



Style 641—Solid Metal Profile

Profile gaskets combine the desirable qualities of a solid metal gasket with the advantages of a reduced area of contact, thereby reducing the bolt stress required to effect a seal. This gasket has the same advantages of strength, heat conductivity, and resistance to temperature, pressure and corrosion as Garlock Style 640.

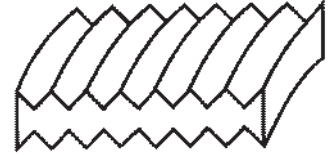

Style 642—Grooved Metal

See Kammprofile, page D-17.

Styles 644 and 645—Single- and Double-Jacketed Profile

Metal-jacketed profile gaskets employ the same principle of reduced contact area while protecting the flange faces from damage due to scoring. This gasket can be manufactured in one of two designs—either single-jacketed (Style 644) or double-jacketed (Style 645).



CERAFELT® is a registered trademark of Thermal Ceramics.

WARNING:

Properties/applications shown throughout this brochure are typical. Your specific application should not be undertaken without independent study and evaluation for suitability. For specific application recommendations consult Garlock. Failure to select the proper sealing products could result in property damage and/or serious personal injury.

Performance data published in this brochure has been developed from field testing, customer field reports and/or in-house testing.

While the utmost care has been used in compiling this brochure, we assume no responsibility for errors. Specifications subject to change without notice. This edition cancels all previous issues. Subject to change without notice.

GRAPHONIC® Metallic Gasket

The superior technology of the GRAPHONIC® family of gaskets ensures excellent sealing performance and reliability, even in the most difficult applications. Each of the three styles combines a corrugated metal core with a compressible sealing element of various materials, for resistance to a wide range of harsh conditions, including extreme temperature, corrosive chemicals, and thermal cycling.

Applications

- Valves
- Pumps
- Flanges
- Heat exchangers
- Vessels

GRAPHONIC® Gasket (Style 603)

With flexible graphite sealing element

- Accommodates a wide range of temperatures
- Seals effectively during thermal cycling
- Fire safe—passed API 6FB fire tests
- Chemically resistant
- Long service life

TEPHONIC® Gasket (Style 604)

With ePTFE sealing element

- Chemically inert
- Forms a tight seal under low bolt load
- Conforms to minor sealing surface imperfections
- Withstands temperatures to 500°F (260°C)

G.E.T.™ Gasket (Style 607)

With graphite and ePTFE sealing element

- Combines fire safety with chemical resistance
- Conforms to minor sealing surface imperfections
- Rigid yet compressible

INCONEL® is a registered trademark of Inco Alloys International, Inc.
INCOLOY® is a registered trademark of Inco Alloys International, Inc.
HASTELLOY® is a registered trademark of Haynes International.
MONEL® is a registered trademark of International Nickel.



Construction

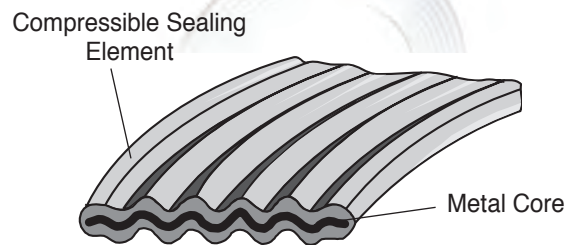

Standard Metals

- 316L Stainless

Also Available

- 304 Stainless
- Carbon steel
- INCONEL® 600
- INCONEL® 625
- INCOLOY® 800
- INCOLOY® 825
- HASTELLOY® C276
- MONEL® 400

Sealing Elements

- Flexible graphite
- ePTFE
- Combination graphite and ePTFE

Engineering Data

	GRAPHONIC®	TEPHONIC® and G.E.T.™
Temperature,		
Minimum:	-400°F (-240°C)	-400°F (-240°C)
Max. in atmosphere:	850°F (454°C)	500°F (260°C)
Max. in steam:	1,200°F (650°C)	500°F (260°C)
Max. continuous:	850°F (454°C)	500°F (260°C)
Pressure, max.:	1,000 psig (70 bar)	
P x T, max.		
1/16" thickness:	700,000 (25,000)†	—
1/8" thickness:	400,000 (13,500)	250,000 (8,500)

† P x T max. = psig x °F (bar x °C)

Note: When approaching maximum temperatures, consult the Garlock Metallic Gasket Engineering Dept. at **1-800-972-7638** or **1-281-459-7200**.

Garlock Kammprofile™ Gasket

Benefits

- Accommodates standard ASME flanges as well as weaker and non-circular flanges
- Seals less-than-perfect flanges
- Handles pressures from vacuum to Class 2500
- Performance replacement for jacketed heat exchanger gaskets
- Fire safe—passed API 6FB fire tests
- Available in heat shield configuration for high temp applications above 850°F (454°C) (see page D-6)

Applications

- Valves
- Pumps
- Flanges
- Heat exchangers
- Vessels

Serrated solid metal core

- Solid metal core resists cold flow, overcompression and blowout
- Rigid core provides exceptional stability, even in large sizes, and facilitates handling and installation
- Available in wide variety of metals

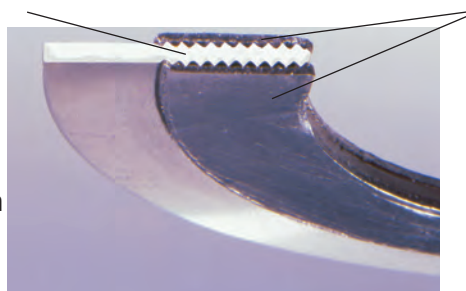

Soft, deformable sealing material

- Under compression, fills seating surface imperfections to form a tight connection
- Seals under low stress—ideal for weaker flanges
- Withstands extreme fluctuations in temperatures and pressures

Style Selection Guide

Garlock Kammprofile Styles	Construction		Centering Ring		Flange			
	Parallel Root	Convex Root	Ring		Male/Female	Tongue/Groove	Flat Face	Raised Face
			Integral	Floating				
642 A	●				●	●		●
642 AR	●		●				●	●
642 AR2	●			●			●	●
642 AC		●			●	●		●
642 ARC		●	●				●	●
642 ARC2		●		●			●	●

- **Parallel root core** is standard design
- **Convex root core** compensates for weaker flanges and resulting flange rotation
- **Integral centering ring** ensures optimum gasket positioning
- **Floating centering ring** allows for expansion and contraction during thermal cycling

Gasket Style	Gasket Factor "M"	Gasket Factor "Y" (psi)
Kammprofile gasket	4.00	1,000*

Note: When designing a flange, a "Y" value of 4,000 psi is suggested.

WARNING:

Properties/applications shown throughout this brochure are typical. Your specific application should not be undertaken without independent study and evaluation for suitability. For specific application recommendations consult Garlock. Failure to select the proper sealing products could result in property damage and/or serious personal injury.

Performance data published in this brochure has been developed from field testing, customer field reports and/or in-house testing.

While the utmost care has been used in compiling this brochure, we assume no responsibility for errors. Specifications subject to change without notice. This edition cancels all previous issues. Subject to change without notice.

Factors Affecting Gasket Performance

A gasket is any deformable material which, when clamped between essentially stationary faces, prevents the passage of media across the gasketed connection.

Compressing the gasket material causes the material to flow into the imperfections of the sealing areas and effect a seal. This seal prevents the escape of the contained media. In order to maintain this condition, sufficient load must be applied to the connection to oppose the hydrostatic end force created by the internal pressure of the system.

Gasket performance depends on a number of factors, including:

1. **Gasket Metal and Filler Material:** The materials must withstand the effects of:
 - a. **Temperature:** Temperature can adversely affect mechanical and chemical properties of the gasket, as well as physical characteristics such as oxidation and resilience.
 - b. **Pressure:** The media or internal piping pressure can blow out the gasket across the flange face.
 - c. **Media:** The gasket materials must be resistant to corrosive attack from the media.

2. **Joint Design:** The force holding the two flanges together must be sufficient to prevent flange separation caused by hydrostatic end force, resulting from the pressure acting on the internal area.
3. **Proper Bolt Load:** If the bolt load is insufficient to deform the gasket, or is so excessive that it crushes the gasket, a leak will occur.
4. **Surface Finish:** If the surface finish is not suitable for the gasket, a seal will not be effected.

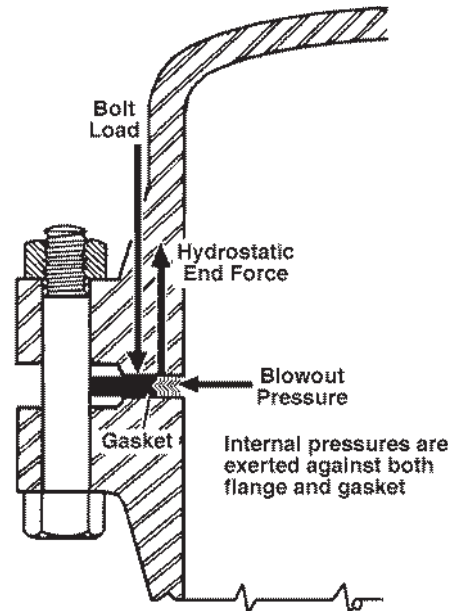

Forces Acting on a Gasket

WARNING:

Properties/applications shown throughout this brochure are typical. Your specific application should not be undertaken without independent study and evaluation for suitability. For specific application recommendations consult Garlock. Failure to select the proper sealing products could result in property damage and/or serious personal injury.

Performance data published in this brochure has been developed from field testing, customer field reports and/or in-house testing.

While the utmost care has been used in compiling this brochure, we assume no responsibility for errors. Specifications subject to change without notice. This edition cancels all previous issues. Subject to change without notice.

Spiral Wound Specifications

Temperature Limits for Common Metals

Material	Minimum		Maximum		Abbreviation
	°F	°C	°F	°C	
304 Stainless Steel	-320	-195	1,400	760	304
316L Stainless Steel	-150	-100	1,400	760	316L
317L Stainless Steel	-150	-100	1,400	760	317L
321 Stainless Steel	-320	-195	1,400	760	321
347 Stainless Steel	-320	-195	1,700	925	347
Carbon Steel	-40	-40	1,000	540	CRS
20Cb-3 (Alloy 20)	-300	-185	1,400	760	A-20
HASTELLOY® B 2	-300	-185	2,000	1,090	HAST B
HASTELLOY® C 276	-300	-185	2,000	1,090	HAST C
INCOLOY® 800	-150	-100	1,600	870	IN 800
INCOLOY® 825	-150	-100	1,600	870	IN 825
INCONEL® 600	-150	-100	2,000	1,090	INC 600
INCONEL® 625	-150	-100	2,000	1,090	INC 625
INCONEL® X750	-150	-100	2,000	1,090	INX
MONEL® 400	-200	-130	1,500	820	MON
Nickel 200	-320	-195	1,400	760	NI
Titanium	-320	-195	2,000	1,090	TI

Guide Ring Color Code*
Yellow
Green
Maroon
Turquoise
Blue
Silver
Black
Brown
Beige
White
White
Gold
Gold
No Color
Orange
Red
Purple

Temperature Limits for Filler Material

Material	Minimum		Maximum COT		Abbreviation
	°F	°C	°F	°C	
Ceramic†	-350	-212	2,000	1,090	CER
Flexible Graphite	-350	-212	850	454	F.G.
PTFE	-400	-240	500	260	PTFE

Stripe Color Code*
Light Green
Gray
White

Standard Tolerances

For windings

Gasket Diameter	ID	OD
Up to 1"	" +1/64" -0	" +0 -1/32"
1" to 24"	" +1/32" -0	" +0 -1/32"
24" to 36"	" +3/64" -0	" +0 -1/16"
36" to 60"	" +1/16" -0	" +0 -1/16"
60" and above	" +3/32" -0	" +0 -3/32"

For spiral wound gaskets not otherwise specified.

Gasket		Width Limits		Compressed Thickness
Thickness	Tolerance	Minimum	Maximum	
0.125"***	±0.005"	3/16"	1"††	0.090 - 0.100"
0.175"***	±0.005"	1/4"	1-1/2"††	0.125 - 0.135"
0.250"***	±0.005"	5/16"	1-1/2"††	0.180 - 0.200"
0.285"***	±0.005"	5/16"	1-1/2"††	0.200 - 0.220"

Available Thicknesses

Winding	Ring(s) Inner & Outer
0.125"	3/32"
0.175"	1/8"
0.250"	3/16"
0.285"	3/16"

HASTELLOY® is a registered trademark of Haynes International.
 INCOLOY® and INCONEL® are registered trademarks of Inco Alloys International, Inc.
 MONEL® is a registered trademark of International Nickel.

Note:

Thickness tolerance is ±0.005" on all gaskets, except +0.010" -0.005" on gaskets with:

- Less than 1" ID and greater than 26" ID
- PTFE filler
- Flange widths of 1" or greater

* ASME B 16.20 standard

† Contact Garlock Engineering when selecting this material.

** Measured across the metallic portion of the gasket not including the filler, which may protrude slightly.

†† Spiral wound gaskets can be made to large maximum widths if required. Call Garlock for details.

Flange Types

Flat Face

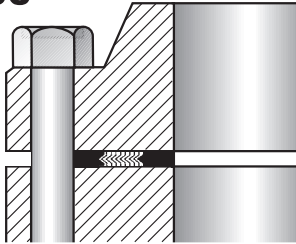

Unconfined Gasket

- Mating faces of both flanges are flat
- Gasket may be ring type, or full face, which covers the entire face both inside and outside the bolts

Male-Female

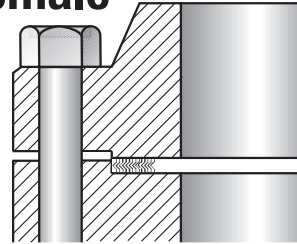

Semi-Confined Gasket

- Depth of female (recessed) face normally equal to or less than height of male (raised) face, to prevent metal-to-metal contact during gasket compression
- Recessed O.D. normally is not more than 1/16" larger than the O.D. of the male face
- Joint must be pried apart for disassembly

Raised Face

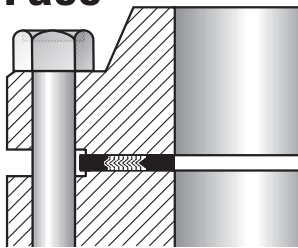

Unconfined Gasket

- Flange sealing surface is reduced to achieve higher seating stress
- Gasket is usually ring type, contained entirely within bolts

Tongue and Groove

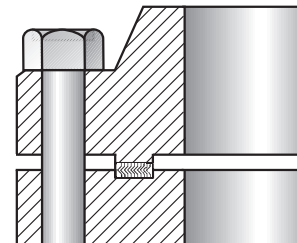

Fully Confined Gasket

- Groove depth is equal to or less than tongue height
- Groove usually not over 1/16" wider than tongue
- Gasket dimensions will match tongue dimensions
- Joint must be pried apart for disassembly

Ring Joint

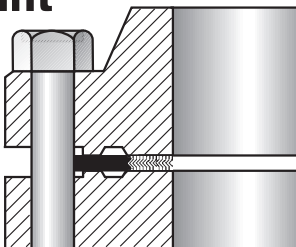

Also Called "API Joint" or "RTJ"

- Both flange faces have matching flat-bottomed grooves with sides tapered from the vertical at 23°
- Gasket seats on flat section of flange between bore and ring joint groove
- Garlock spiral wound gaskets can replace solid metal ring gaskets

Groove to Flat

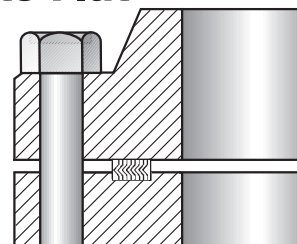

Fully Confined Gasket

- One flange face is flat, the other is recessed
- For applications requiring accurate control of gasket compression
- Only resilient gaskets are recommended—spiral wound, hollow metal O-ring, pressure-actuated, and metal-jacketed gaskets

Gasket Selection By Flange Type

	RW	RWI	EDGE®	TANDEM	SW	MC	MCR	HH	RW-RJ	RWI-RJ	LMF	LTG	STG	HEAT SHIELD™
Flat Face	■	■	■	■		■	■	■						■
Raised Face	■	■	■	■			■							■
Ring Joint									■	■				
Male-Female					■	■					■	■	■	
Tongue-&-Groove					■	■						■	■	
Groove-to-Flat					■	■								

Flange Surface Finish

The surface finish of a flange is described as follows:

Roughness

- Average of peaks and valleys measured from mid-line of flange surface (in millionths of an inch)
- Expressed as rms (root mean square) or AA (arithmetic average) or AARH (arithmetic average roughness height)

Lay

- The direction of the predominant surface-roughness pattern
- Example: multidirectional, phonographic spiral serrations, etc.

Waviness

- The departure from overall flatness
- Measured in thousandths or fractions of an inch

Recommended Values

Spiral Wound Gaskets	125-250 rms
GRAPHONIC® Gaskets	125-250 rms
Kammprofile Gaskets	125-250 rms
Jacketed or Metal Clad Gaskets	63-80 rms
Solid Metal Gaskets	63-80 rms

Note:

These values are suggested only and not mandatory; however they are based upon the best cross-section of successful design experience currently available.

WARNING:

Properties/applications shown throughout this brochure are typical. Your specific application should not be undertaken without independent study and evaluation for suitability. For specific application recommendations consult Garlock. Failure to select the proper sealing products could result in property damage and/or serious personal injury.

Performance data published in this brochure has been developed from field testing, customer field reports and/or in-house testing.

While the utmost care has been used in compiling this brochure, we assume no responsibility for errors. Specifications subject to change without notice. This edition cancels all previous issues. Subject to change without notice.

Maximum Flange Bore for FLEXSEAL® RW Gaskets

Flange Size (NPS)	Pressure Class												
	75	150	300	400	600	900 ¹	1500 ¹	2500 ¹					
1/2"	No recommendation in 75 lb. flanges	Weld-neck only ²		No flanges. Use Class 600	Weld-neck only ²	No flanges. Use Class 1500	Weld-neck only ²						
3/4"					Weld-neck only ²								
1"		Slip-on ³ Weld-neck ²			Slip-on ³ Weld-neck ²								
1 1/4"					Slip-on ³ Weld-neck ²								
1 1/2"		Slip-on ³ Weld-neck, any bore		Slip-on ³ Weld-neck, any bore									
2"				Slip-on ³ Weld-neck, any bore									
2 1/2"		Slip-on, Weld-neck, any bore		Slip-on, Weld-neck, any bore	Weld-neck with Standard wall bore (includes nozzle ⁴ but excludes Slip-on)		Weld-neck w/ Schedule 60 bore						
3"				Slip-on, Weld-neck, any bore									
4"				Slip-on, Weld-neck, any bore									
6"				Slip-on, Weld-neck, any bore									
8"		Slip-on, Weld-neck, any bore		Weld-neck with Schedule 10S bore described in ASME B36.19M (includes nozzle ⁴ but excludes Slip-on)		Weld-neck w/ Standard wall bore (excludes nozzle and Slip-on)		Weld-neck w/ Schedule 80 bore					
10"								Weld-neck w/ Schedule 80 bore					
12"								Weld-neck with Schedule 10 bore described in ASME B36.10M (excludes nozzle ⁴ and Slip-on ⁵)		Weld-neck w/ Standard wall bore (excludes nozzle and Slip-on)		No flanges	
14"													
16"		Weld-neck with Schedule 10 bore described in ASME B36.10M (excludes nozzle ⁴ and Slip-on ⁵)		Weld-neck w/ Standard wall bore (excludes nozzle and Slip-on)		Weld-neck w/ Sched. 40 bore							
18"													
20"	Weld-neck with Schedule 10 bore described in ASME B36.10M (excludes nozzle ⁴ and Slip-on ⁵)		Weld-neck w/ Standard wall bore (excludes nozzle and Slip-on)		Weld-neck w/ Sched. 40 bore								
24"													

Notes:

1. Inner rings are recommended for all graphite filled gaskets, required for all PTFE filled gaskets, and for NPS 24 and larger in Class 900, NPS 12 and larger in Class 1500, and NPS 4 and larger in Class 2500. (See page D-3 for full description) These inner rings may extend into the pipe bore a maximum of 0.06" (1.5 mm) under the worst combination or maximum bore, eccentric installation, and additive tolerances. Purchaser should specify inner ring material.
2. In these sizes the gasket is suitable for a weld-neck flange with a standard wall bore, if the gasket and the flange are assembled concentrically. This also applies to a nozzle. It is the user's responsibility to determine if the gasket is satisfactory for the flange of any larger bore.
3. Gaskets in these sizes are suitable for slip-on flanges only if the gaskets and flanges are assembled concentrically.

4. A nozzle is a long welded neck; the bore equals the flange NPS.
5. An NPS 24 gasket is suitable for nozzles.

WARNING:

Properties/applications shown throughout this brochure are typical. Your specific application should not be undertaken without independent study and evaluation for suitability. For specific application recommendations consult Garlock. Failure to select the proper sealing products could result in property damage and/or serious personal injury.

Performance data published in this brochure has been developed from field testing, customer field reports and/or in-house testing.

While the utmost care has been used in compiling this brochure, we assume no responsibility for errors. Specifications subject to change without notice. This edition cancels all previous issues. Subject to change without notice.

Styles RW, RWI Dimensions 1/4" to 24" Flanges

ASME B16.20 Gaskets for ASME B16.5 Flanges

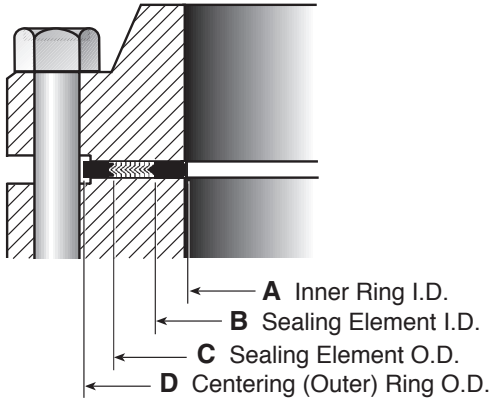

Class 150

Size NPS	Inner Ring	Sealing Element		Outer Ring
	Inside (A) Diameter	Inside (B) Diameter	Outside (C) Diameter	Outside (D) Diameter
1/4*	—	0.50	0.88	1.75
1/2	0.56	0.75	1.25	1.88
3/4	0.81	1.00	1.56	2.25
1	1.06	1.25	1.88	2.63
1-1/4	1.50	1.88	2.38	3.00
1-1/2	1.75	2.13	2.75	3.38
2	2.19	2.75	3.38	4.13
2-1/2	2.62	3.25	3.88	4.88
3	3.19	4.00	4.75	5.38
3-1/2*	—	4.50	5.25	6.38
4	4.19	5.00	5.88	6.88
4-1/2*	—	5.50	6.50	7.00
5	5.19	6.13	7.00	7.75
6	6.19	7.19	8.25	8.75
8	8.50	9.19	10.38	11.00
10	10.56	11.31	12.50	13.38
12	12.50	13.38	14.75	16.13
14	13.75	14.63	16.00	17.75
16	15.75	16.63	18.25	20.25
18	17.69	18.69	20.75	21.63
20	19.69	20.69	22.75	23.88
24	23.75	24.75	27.00	28.25

* ASME B16.20 does not include dimensions for NPS 1/4, 3-1/2 or 4-1/2, or Class 400 flanges up to NPS 3 and Class 900 flanges up to NPS 2-1/2. Dimensions in inches.

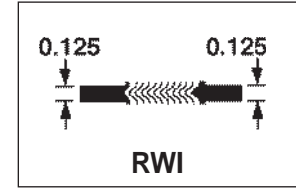
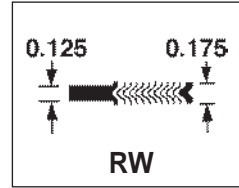

Class 300

Size NPS	Inner Ring	Sealing Element		Outer Ring
	Inside (A) Diameter	Inside (B) Diameter	Outside (C) Diameter	Outside (D) Diameter
1/4*	—	0.50	0.88	1.75
1/2	0.56	0.75	1.25	2.13
3/4	0.81	1.00	1.56	2.63
1	1.06	1.25	1.88	2.88
1-1/4	1.50	1.88	2.38	3.25
1-1/2	1.75	2.13	2.75	3.75
2	2.19	2.75	3.38	4.38
2-1/2	2.62	3.25	3.88	5.13
3	3.19	4.00	4.75	5.88
3-1/2*	—	4.50	5.25	6.50
4	4.19	5.00	5.88	7.13
4-1/2*	—	5.50	6.50	7.75
5	5.19	6.13	7.00	8.50
6	6.19	7.19	8.25	9.88
8	8.50	9.19	10.38	12.13
10	10.56	11.31	12.50	14.25
12	12.50	13.38	14.75	16.63
14	13.75	14.63	16.00	19.13
16	15.75	16.63	18.25	21.25
18	17.69	18.69	20.75	23.50
20	19.69	20.69	22.75	25.75
24	23.75	24.75	27.00	30.50

Notes:

1. Inner rings are recommended for all graphite filled gaskets, required for all PTFE filled gaskets, and for NPS 24 and larger in Class 900, NPS 12 and larger in Class 1500, and NPS 4 and larger in Class 2500.
2. The gasket outside diameter tolerance for NPS 1/2 through NPS 8 is ± 0.03 "; for NPS 10 through NPS 24, $+0.06$ ", -0.03 ".
3. The gasket inside diameter tolerance for NPS 1/2 through NPS 8 is ± 0.016 "; for NPS 10 through NPS 24, ± 0.03 ".
4. The centering ring outside diameter tolerance is ± 0.03 ".
5. There are no Class 400 flanges in NPS 1/2 through NPS 3 (use Class 600), Class 900 flanges in NPS 1/2 through NPS 2-1/2 (use Class 1500), or Class 2500 flanges NPS 14 and larger.

Styles RW, RWI Dimensions 1/4" to 24" Flanges

Class 400

Size NPS	Inner Ring	Sealing Element		Outer Ring
	Inside (A) Diameter	Inside (B) Diameter	Outside (C) Diameter	Outside (D) Diameter
1/4*	—	0.50	0.88	1.75
1/2*	—	0.75	1.25	2.13
3/4*	—	1.00	1.56	2.63
1*	—	1.25	1.88	2.88
1-1/4*	—	1.88	2.38	3.25
1-1/2*	—	2.13	2.75	3.75
2*	—	2.75	3.38	4.38
2-1/2*	—	3.25	3.88	5.13
3*	—	4.00	4.75	5.88
3-1/2*	—	4.13	5.25	6.38
4	4.04	4.75	5.88	7.00
4-1/2*	—	5.31	6.50	7.63
5	5.05	5.81	7.00	8.38
6	6.10	6.88	8.25	9.75
8	8.10	8.88	10.38	12.00
10	10.05	10.81	12.50	14.13
12	12.10	12.88	14.75	16.50
14	13.50	14.25	16.00	19.00
16	15.35	16.25	18.25	21.13
18	17.25	18.50	20.75	23.38
20	19.25	20.50	22.75	25.50
24	23.25	24.75	27.00	30.25

Class 600

Size NPS	Inner Ring	Sealing Element		Outer Ring
	Inside (A) Diameter	Inside (B) Diameter	Outside (C) Diameter	Outside (D) Diameter
1/4*	—	0.50	0.88	1.75
1/2	0.56	0.75	1.25	2.13
3/4	0.81	1.00	1.56	2.63
1	1.06	1.25	1.88	2.88
1-1/4	1.50	1.88	2.38	3.25
1-1/2	1.75	2.13	2.75	3.75
2	2.19	2.75	3.38	4.38
2-1/2	2.62	3.25	3.88	5.13
3	3.19	4.00	4.75	5.88
3-1/2*	—	4.13	5.25	6.38
4	4.04	4.75	5.88	7.63
4-1/2*	—	5.31	6.50	8.25
5	5.05	5.81	7.00	9.50
6	6.10	6.88	8.25	10.50
8	8.10	8.88	10.38	12.63
10	10.05	10.81	12.50	15.75
12	12.10	12.88	14.75	18.00
14	13.50	14.25	16.00	19.38
16	15.35	16.25	18.25	22.25
18	17.25	18.50	20.75	24.13
20	19.25	20.50	22.75	26.88
24	23.25	24.75	27.00	31.13

Class 900

Size NPS	Inner Ring	Sealing Element		Outer Ring
	Inside (A) Diameter	Inside (B) Diameter	Outside (C) Diameter	Outside (D) Diameter
1/2*	—	0.75	1.25	2.50
3/4*	—	1.00	1.56	2.75
1*	—	1.25	1.88	3.13
1-1/4*	—	1.56	2.38	3.50
1-1/2*	—	1.88	2.75	3.88
2*	—	2.31	3.38	5.63
2-1/2*	—	2.75	3.88	6.50
3	3.10	3.75	4.75	6.63
3-1/2*	—	4.13	5.25	7.50
4	4.04	4.75	5.88	8.13
4-1/2*	—	5.31	6.50	9.38
5	5.05	5.81	7.00	9.75
6	6.10	6.88	8.25	11.38
8	7.75	8.75	10.13	14.13
10	9.69	10.88	12.25	17.13
12	11.50	12.75	14.50	19.63
14	12.63	14.00	15.75	20.50
16	14.75	16.25	18.00	22.63
18	16.75	18.25	20.50	25.13
20	19.00	20.50	22.50	27.50
24	23.25 (5)	24.75	26.75	33.00

* ASME B16.20 does not include dimensions for NPS 1/4, 3-1/2 or 4-1/2, or Class 400 flanges up to NPS 3 and Class 900 flanges up to NPS 2-1/2. Dimensions in inches.

Notes:

1. Inner rings are recommended for all graphite filled gaskets, required for all PTFE filled gaskets, and for NPS 24 and larger in Class 900, NPS 12 and larger in Class 1500, and NPS 4 and larger in Class 2500.
2. The gasket outside diameter tolerance for NPS 1/2 through NPS 8 is ± 0.03 "; for NPS 10 through NPS 24, $+0.06$ ", -0.03 ".
3. The gasket inside diameter tolerance for NPS 1/2 through NPS 8 is ± 0.016 "; for NPS 10 through NPS 24, ± 0.03 ".
4. The centering ring outside diameter tolerance is ± 0.03 ".
5. There are no Class 400 flanges in NPS 1/2 through NPS 3 (use Class 600), Class 900 flanges in NPS 1/2 through NPS 2-1/2 (use Class 1500), or Class 2500 flanges NPS 14 and larger.

Styles RW, RWI Dimensions 1/4" to 24" Flanges

ASME B16.20 Gaskets for ASME B16.5 Flanges

Class 1500

Size NPS	Inner Ring	Sealing Element		Outer Ring
	Inside (A) Diameter	Inside (B) Diameter	Outside (C) Diameter	Outside (D) Diameter
1/2	0.56	0.75	1.25	2.50
3/4	0.81	1.00	1.56	2.75
1	1.06	1.25	1.88	3.13
1-1/4	1.31 (4)	1.56	2.38	3.50
1-1/2	1.63 (4)	1.88	2.75	3.88
2	2.06 (4)	2.31	3.38	5.63
2-1/2	2.50 (4)	2.75	3.88	6.50
3	3.10	3.63	4.75	6.88
3-1/2*	—	4.13	5.25	7.38
4	3.85	4.63	5.88	8.25
4-1/2*	—	5.31	6.50	9.13
5	4.90	5.63	7.00	10.00
6	5.80	6.75	8.25	11.13
8	7.75	8.50	10.13	13.88
10	9.69	10.50	12.25	17.13
12	11.50 (5)	12.75	14.50	20.50
14	12.63 (5)	14.25	15.75	22.75
16	14.50 (5)	16.00	18.00	25.25
18	16.75 (5)	18.25	20.50	27.75
20	18.75 (5)	20.25	22.50	29.75
24	22.75 (5)	24.25	26.75	35.50

Class 2500

Size NPS	Inner Ring	Sealing Element		Outer Ring
	Inside (A) Diameter	Inside (B) Diameter	Outside (C) Diameter	Outside (D) Diameter
1/2	0.56	0.75	1.25	2.75
3/4	0.81	1.00	1.56	3.00
1	1.06	1.25	1.88	3.38
1-1/4	1.31 (4)	1.56	2.38	4.13
1-1/2	1.63 (4)	1.88	2.75	4.63
2	2.06 (4)	2.31	3.38	5.75
2-1/2	2.50 (4)	2.75	3.88	6.63
3	3.10	3.63	4.75	7.75
4	3.85 (5)	4.63	5.88	9.25
5	4.90 (5)	5.63	7.00	11.00
6	5.80 (5)	6.75	8.25	12.50
8	7.75 (5)	8.50	10.13	15.25
10	9.69 (5)	10.63	12.25	18.75
12	11.50 (5)	12.50	14.50	21.63

* ASME B16.20 does not include dimensions for NPS 1/4, 3-1/2 or 4-1/2, or Class 400 flanges up to NPS 3 and Class 900 flanges up to NPS 2-1/2.
Dimensions in inches.

Notes:

1. Inner rings are recommended for all graphite filled gaskets, required for all PTFE filled gaskets, and for NPS 24 and larger in Class 900, NPS 12 and larger in Class 1500, and NPS 4 and larger in Class 2500.
2. The gasket outside diameter tolerance for NPS 1/2 through NPS 8 is ± 0.03 "; for NPS 10 through NPS 24, $+0.06$ ", -0.03 ".
3. The gasket inside diameter tolerance for NPS 1/2 through NPS 8 is ± 0.016 "; for NPS 10 through NPS 24, ± 0.03 ".
4. The centering ring outside diameter tolerance is ± 0.03 ".
5. There are no Class 400 flanges in NPS 1/2 through NPS 3 (use Class 600), Class 900 flanges in NPS 1/2 through NPS 2-1/2 (use Class 1500), or Class 2500 flanges NPS 14 and larger.

WARNING:

Properties/applications shown throughout this brochure are typical. Your specific application should not be undertaken without independent study and evaluation for suitability. For specific application recommendations consult Garlock. Failure to select the proper sealing products could result in property damage and/or serious personal injury.

Performance data published in this brochure has been developed from field testing, customer field reports and/or in-house testing.

While the utmost care has been used in compiling this brochure, we assume no responsibility for errors. Specifications subject to change without notice. This edition cancels all previous issues. Subject to change without notice.

Styles RW, RWI Dimensions 22-60" Series A Flanges

ASME B16.20 Gaskets for ASME B16.47 Series A Flanges (MSS SP-44)

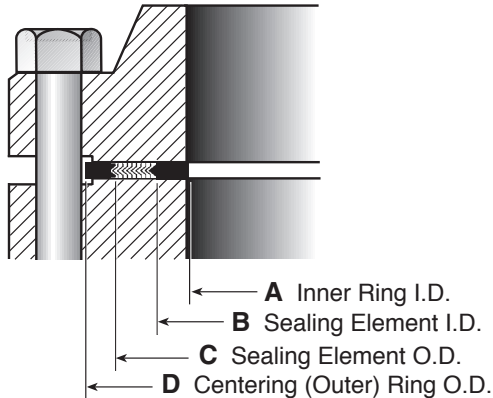

Class 150

Size NPS	Inner Ring	Sealing Element		Outer Ring
	Inside (A) Diameter	Inside (B) Diameter	Outside (C) Diameter	Outside (D) Diameter
22*	—	22.75	24.00	26.00
26	25.75	26.50	27.75	30.50
28	27.75	28.50	29.75	32.75
30	29.75	30.50	31.75	34.75
32	31.75	32.50	33.88	37.00
34	33.75	34.50	35.88	39.00
36	35.75	36.50	38.13	41.25
38	37.75	38.50	40.13	43.75
40	39.75	40.50	42.13	45.75
42	41.75	42.50	44.25	48.00
44	43.75	44.50	46.38	50.25
46	45.75	46.50	48.38	52.25
48	47.75	48.50	50.38	54.50
50	49.75	50.50	52.50	56.50
52	51.75	52.50	54.50	58.75
54	53.50	54.50	56.50	61.00
56	55.50	56.50	58.50	63.25
58	57.50	58.50	60.50	65.50
60	59.50	60.50	62.50	67.50

Class 300

Size NPS	Inner Ring	Sealing Element		Outer Ring
	Inside (A) Diameter	Inside (B) Diameter	Outside (C) Diameter	Outside (D) Diameter
22*	—	22.75	24.75	27.75
26	25.75	27.00	29.00	32.88
28	27.75	29.00	31.00	35.38
30	29.75	31.25	33.25	37.50
32	31.75	33.50	35.50	39.63
34	33.75	35.50	37.50	41.63
36	35.75	37.63	39.63	44.00
38	37.50	38.50	40.00	41.50
40	39.50	40.25	42.13	43.88
42	41.50	42.25	44.13	45.88
44	43.50	44.50	46.50	48.00
46	45.38	46.38	48.38	50.13
48	47.63	48.63	50.63	52.13
50	49.00	51.00	53.00	54.25
52	52.00	53.00	55.00	56.25
54	53.25	55.25	57.25	58.75
56	55.25	57.25	59.25	60.75
58	57.00	59.50	61.50	62.75
60	60.00	61.50	63.50	64.75

Class 400

Size NPS	Inner Ring	Sealing Element		Outer Ring
	Inside (A) Diameter	Inside (B) Diameter	Outside (C) Diameter	Outside (D) Diameter
22*	—	22.75	24.75	27.63
26	26.00	27.00	29.00	32.75
28	28.00	29.00	31.00	35.13
30	29.75	31.25	33.25	37.25
32	32.00	33.50	35.50	39.50
34	34.00	35.50	37.50	41.50
36	36.13	37.63	39.63	44.00
38	37.50	38.25	40.25	42.25
40	39.38	40.38	42.38	44.38
42	41.38	42.38	44.38	46.38
44	43.50	44.50	46.50	48.50
46	46.00	47.00	49.00	50.75
48	47.50	49.00	51.00	53.00
50	49.50	51.00	53.00	55.25
52	51.50	53.00	55.00	57.25
54	53.25	55.25	57.25	59.75
56	55.25	57.25	59.25	61.75
58	57.25	59.25	61.25	63.75
60	59.75	61.75	63.75	66.25

Notes:

1. Inner rings are recommended for all graphite filled gaskets, required for all PTFE filled gaskets, and for NPS 24 and larger in Class 900, NPS 12 and larger in Class 1500, and NPS 4 and larger in Class 2500.
2. The gasket inside diameter tolerance for NPS 26 through NPS 34 is ± 0.03 "; for NPS 36 through NPS 60 is ± 0.05 ".
3. The gasket outside diameter tolerance for NPS 26 through NPS 60 is ± 0.06 ".
4. The centering ring outside diameter tolerance is ± 0.03 ".
5. There are no Class 900 flanges in NPS 50 and larger.

Styles RW, RWI Dimensions 22-60" Series A Flanges

ASME B16.20 Gaskets for ASME B16.47 Series A Flanges (MSS SP-44)

Class 600

Size NPS	Inner Ring	Sealing Element		Outer Ring
	Inside (A) Diameter	Inside (B) Diameter	Outside (C) Diameter	Outside (D) Diameter
22*	—	22.75	24.75	28.88
26	25.50	27.00	29.00	34.13
28	27.50	29.00	31.00	36.00
30	29.75	31.25	33.25	38.25
32	32.00	33.50	35.50	40.25
34	34.00	35.50	37.50	42.25
36	36.13	37.63	39.63	44.50
38	37.50	39.00	41.00	43.50
40	39.75	41.25	43.25	45.50
42	42.00	43.50	45.50	48.00
44	43.75	45.75	47.75	50.00
46	45.75	47.75	49.75	52.25
48	48.00	50.00	52.00	54.75
50	50.00	52.00	54.00	57.00
52	52.00	54.00	56.00	59.00
54	54.25	56.25	58.25	61.25
56	56.25	58.25	60.25	63.50
58	58.00	60.50	62.50	65.50
60	60.25	62.75	64.75	68.25

Class 900

Size NPS	Inner Ring	Sealing Element		Outer Ring
	Inside (A) Diameter	Inside (B) Diameter	Outside (C) Diameter	Outside (D) Diameter
22*	—	24.25	27.00	33.00
26	26.00	27.00	29.00	34.75 ⁽¹⁾
28	28.00	29.00	31.00	37.25 ⁽¹⁾
30	30.25	31.25	33.25	39.75 ⁽¹⁾
32	32.00	33.50	35.50	42.25 ⁽¹⁾
34	34.00	35.50	37.50	44.75 ⁽¹⁾
36	36.25	37.75	39.75	47.25 ⁽¹⁾
38	39.75	40.75	42.75	47.25 ⁽¹⁾
40	41.75	43.25	45.25	49.25 ⁽¹⁾
42	43.75	45.25	47.25	51.25 ⁽¹⁾
44	45.50	47.50	49.50	53.88 ⁽¹⁾
46	48.00	50.00	52.00	56.50 ⁽¹⁾
48	50.00	52.00	54.00	58.50 ⁽¹⁾

Notes:

1. Inner rings are recommended for all graphite filled gaskets, required for all PTFE filled gaskets, and for NPS 24 and larger in Class 900, NPS 12 and larger in Class 1500, and NPS 4 and larger in Class 2500.
2. The gasket inside diameter tolerance for NPS 26 through NPS 34 is ± 0.03 "; for NPS 36 through NPS 60 is ± 0.05 ".
3. The gasket outside diameter tolerance for NPS 26 through NPS 60 is ± 0.06 ".
4. The centering ring outside diameter tolerance is ± 0.03 ".
5. There are no Class 900 flanges in NPS 50 and larger.

WARNING:

Properties/applications shown throughout this brochure are typical. Your specific application should not be undertaken without independent study and evaluation for suitability. For specific application recommendations consult Garlock. Failure to select the proper sealing products could result in property damage and/or serious personal injury.

Performance data published in this brochure has been developed from field testing, customer field reports and/or in-house testing.

While the utmost care has been used in compiling this brochure, we assume no responsibility for errors. Specifications subject to change without notice. This edition cancels all previous issues. Subject to change without notice.

Styles RW, RWI Dimensions 26-60" Series B Flanges

ASME B16.20 Gaskets for ASME B16.47 Series B Flanges (API-605)

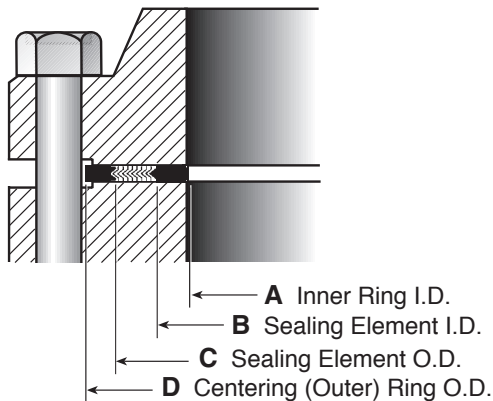

Notes:

1. Inner rings are recommended for all graphite filled gaskets, required for all PTFE filled gaskets and for NPS 24 and larger in Class 900, NPS 12 and larger in Class 1500, and NPS 4 and larger in Class 2500.
2. The gasket inside diameter tolerance for NPS 26 through NPS 34 is ± 0.03 "; for NPS 36 through NPS 60 is ± 0.05 ".
3. The gasket outside diameter tolerance for NPS 26 through NPS 60 is ± 0.06 ".
4. The centering ring outside diameter tolerance is ± 0.03 ".
5. There are no Class 900 flanges in NPS 50 and larger.

Class 150

Size NPS	Inner Ring	Sealing Element		Outer Ring
	Inside (A) Diameter	Inside (B) Diameter	Outside (C) Diameter	Outside (D) Diameter
26	25.75	26.50	27.50	28.56
28	27.75	28.50	29.50	30.56
30	29.75	30.50	31.50	32.56
32	31.75	32.50	33.50	34.69
34	33.75	34.50	35.75	36.81
36	35.75	36.50	37.75	38.88
38	37.75	38.37	39.75	41.13
40	39.75	40.25	41.88	43.13
42	41.75	42.50	43.88	45.13
44	43.75	44.25	45.88	47.13
46	45.75	46.50	48.19	49.44
48	47.75	48.50	50.00	51.44
50	49.75	50.50	52.19	53.44
52	51.75	52.50	54.19	55.44
54	53.75	54.50	56.00	57.63
56	56.00	56.88	58.18	59.63
58	58.19	59.07	60.19	62.19
60	60.44	61.31	62.44	64.19

Class 75

Large Diameter Weld Neck Flanges

Size NPS	Sealing Element		Outer Ring
	Inside (B) Diameter	Outside (C) Diameter	Outside (D) Diameter
26	26.25	27.00	27.88
28	28.25	29.13	29.88
30	30.25	31.13	31.88
32	32.25	33.13	33.88
34	34.25	35.13	35.88
36	36.25	37.25	38.31
38	38.25	39.31	40.31
40	40.25	41.31	42.31
42	42.25	43.25	44.31
44	44.25	45.50	46.50
46	46.25	47.50	48.50
48	48.38	49.50	50.50
50	50.25	51.50	52.50
52	52.38	53.63	54.63
54	54.38	55.63	56.63
56	56.50	57.88	58.88
58	58.50	59.88	60.88
60	60.50	61.75	62.88

Class 300

Size NPS	Inner Ring	Sealing Element		Outer Ring
	Inside (A) Diameter	Inside (B) Diameter	Outside (C) Diameter	Outside (D) Diameter
26	25.75	26.50	28.00	30.38
28	27.75	28.50	30.00	32.50
30	29.75	30.50	32.00	34.88
32	31.75	32.50	34.00	37.00
34	33.75	34.50	36.00	39.13
36	35.75	36.50	38.00	41.25
38	38.25	39.75	41.25	43.25
40	40.25	41.75	43.25	45.25
42	42.75	43.75	45.25	47.25
44	44.25	45.75	47.25	49.25
46	46.38	47.88	49.38	51.88
48	48.50	49.75	51.63	53.88
50	49.88	51.88	53.38	55.88
52	51.88	53.88	55.38	57.88
54	53.75	55.25	57.25	60.25
56	56.25	58.25	60.00	62.75
58	58.44	60.44	61.94	65.19
60	61.31	62.56	64.19	67.19

Styles RW, RWI Dimensions 26-60" Series B Flanges

ASME B16.20 Gaskets for ASME B16.47 Series B Flanges (API-605)

Class 400

Size NPS	Inner Ring	Sealing Element		Outer Ring
	Inside (A) Diameter	Inside (B) Diameter	Outside (C) Diameter	Outside (D) Diameter
26	25.75	26.25	27.50	29.38
28	27.63	28.13	29.50	31.50
30	29.63	30.13	31.75	33.75
32	31.50	32.00	33.88	35.88
34	33.50	34.13	35.88	37.88
36	35.38	36.13	38.00	40.25
38	37.50	38.25	40.25	42.25
40	39.38	40.38	42.38	44.38
42	41.38	42.38	44.38	46.38
44	43.50	44.50	46.50	48.50
46	46.00	47.00	49.00	50.75
48	47.50	49.00	51.00	53.00
50	49.50	51.00	53.00	55.25
52	51.50	53.00	55.00	57.25
54	53.25	55.25	57.25	59.75
56	55.25	57.25	59.25	61.75
58	57.25	59.25	61.25	63.75
60	59.75	61.75	63.75	66.25

Class 600

Size NPS	Inner Ring	Sealing Element		Outer Ring
	Inside (A) Diameter	Inside (B) Diameter	Outside (C) Diameter	Outside (D) Diameter
26	25.38	26.13	28.13	30.13
28	27.25	27.75	29.75	32.25
30	29.63	30.63	32.63	34.63
32	31.25	32.75	34.75	36.75
34	33.50	35.00	37.00	39.25
36	35.50	37.00	39.00	41.25
38	37.50	39.00	41.00	43.50
40	39.75	41.25	43.25	45.50
42	42.00	43.50	45.50	48.00
44	43.75	45.75	47.75	50.00
46	45.75	47.75	49.75	52.25
48	48.00	50.00	52.00	54.75
50	50.00	52.00	54.00	57.00
52	52.00	54.00	56.00	59.00
54	54.25	56.25	58.25	61.25
56	56.25	58.25	60.25	63.50
58	58.00	60.50	62.50	65.50
60	60.25	62.75	64.75	68.25

Class 900

Size NPS	Inner Ring	Sealing Element		Outer Ring
	Inside (A) Diameter	Inside (B) Diameter	Outside (C) Diameter	Outside (D) Diameter
26	26.25 ⁽¹⁾	27.25	29.50	33.00
28	28.25 ⁽¹⁾	29.25	31.50	35.50
30	30.75 ⁽¹⁾	31.75	33.75	37.75
32	33.00 ⁽¹⁾	34.00	36.00	40.00
34	35.25 ⁽¹⁾	36.25	38.25	42.25
36	36.25 ⁽¹⁾	37.25	39.25	44.25
38	39.75 ⁽¹⁾	40.75	42.75	47.25
40	41.75 ⁽¹⁾	43.25	45.25	49.25
42	43.75 ⁽¹⁾	45.25	47.25	51.25
44	45.50 ⁽¹⁾	47.50	49.50	53.88
46	48.00 ⁽¹⁾	50.00	52.00	56.50
48	50.00 ⁽¹⁾	52.00	54.00	58.50

Notes:

1. Inner rings are recommended for all graphite filled gaskets, required for all PTFE filled gaskets, and for NPS 24 and larger in Class 900, NPS 12 and larger in Class 1500, and NPS 4 and larger in Class 2500.
2. The gasket inside diameter tolerance for NPS 26 through NPS 34 is ± 0.03 "; for NPS 36 through NPS 60 is ± 0.05 ".
3. The gasket outside diameter tolerance for NPS 26 through NPS 60 is ± 0.06 ".
4. The centering ring outside diameter tolerance is ± 0.03 ".
5. There are no Class 900 flanges in NPS 50 and larger.

WARNING:

Properties/applications shown throughout this brochure are typical. Your specific application should not be undertaken without independent study and evaluation for suitability. For specific application recommendations consult Garlock. Failure to select the proper sealing products could result in property damage and/or serious personal injury.

Performance data published in this brochure has been developed from field testing, customer field reports and/or in-house testing.

While the utmost care has been used in compiling this brochure, we assume no responsibility for errors. Specifications subject to change without notice. This edition cancels all previous issues. Subject to change without notice.

Style RW Dimensions Other Large Diameter Flanges, 26-96"

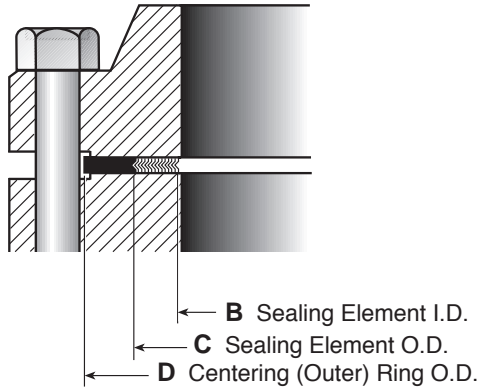

Class 75 Slip-On and Blind

Size NPS	Sealing Element		Outer Ring
	Inside (B) Diameter	Outside (C) Diameter	Outside (D) Diameter
26	27.00	28.25	30.13
28	29.00	30.25	32.13
30	31.00	32.25	34.13
32	33.13	34.38	36.38
34	35.13	36.50	38.38
36	37.13	38.50	40.38
42	43.25	44.75	46.63
48	49.25	50.88	52.63
54	55.38	57.75	59.13
60	61.38	63.38	65.13
66	67.50	69.50	71.75
72	73.50	75.50	77.75

Class 75 Weld Neck and Blind

Size NPS	Sealing Element		Outer Ring
	Inside (B) Diameter	Outside (C) Diameter	Outside (D) Diameter
26	26.50	27.75	28.75
28	28.50	29.75	30.75
30	30.50	31.75	32.75
32	32.50	33.75	35.13
34	34.50	35.88	37.13
36	36.50	37.88	39.13
42	42.50	44.00	45.63
48	48.50	50.13	51.63
54	54.50	56.38	57.88
60	60.50	62.50	63.88
66	66.50	68.50	70.25
72	72.50	74.50	76.25

Class 125

Size NPS	Sealing Element		Outer Ring
	Inside (B) Diameter	Outside (C) Diameter	Outside (D) Diameter
22	22.75	24.00	26.00
26	26.50	27.75	30.50
28	28.50	29.75	32.75
30	30.50	31.75	34.75
32	32.50	33.88	37.00
34	34.50	35.88	39.00
36	36.50	38.13	41.25
38	38.50	40.13	43.75
40	40.50	42.13	45.75
42	42.50	44.25	48.00
44	44.50	46.38	50.25
46	46.50	48.38	52.25
48	48.50	50.38	54.50
50	50.50	52.50	56.50
52	52.50	54.50	58.75
54	54.50	56.50	61.00
60	60.50	62.50	67.50
66	71.00	72.75	74.25
72	77.50	79.25	80.75
84	90.25	92.00	93.50
96	103.00	104.75	106.25

Style RW Dimensions Other Large Diameter Flanges, 26-96"

Class 175

Size NPS	Sealing Element		Outer Ring
	Inside (B) Diameter	Outside (C) Diameter	Outside (D) Diameter
26	26.50	27.75	29.13
28	28.50	29.75	31.13
30	30.50	31.75	33.38
32	32.50	33.75	35.38
34	34.50	35.88	37.50
36	36.50	37.88	39.50
38	38.50	39.88	41.50
40	40.50	42.00	43.50
42	42.50	44.00	45.88
44	44.50	46.00	47.88
46	46.50	48.00	49.88
48	48.50	50.13	51.88
50	50.50	52.25	53.88
52	52.50	54.38	56.13
54	54.50	56.75	58.13
60	60.50	62.50	64.13
66	67.88	68.88	70.13
72	73.38	75.13	76.63
84	87.00	88.75	90.25
96	99.00	100.75	102.25

Class 250

Size NPS	Sealing Element		Outer Ring
	Inside (B) Diameter	Outside (C) Diameter	Outside (D) Diameter
26	26.50	27.75	32.75
28	28.50	29.75	35.25
30	30.50	31.75	37.50
32	32.50	33.88	39.75
34	34.50	35.88	41.75
36	36.50	38.13	44.00
38	38.50	40.13	46.00
40	40.50	42.13	48.25
42	42.50	44.25	50.75
44	44.50	46.38	53.00
46	46.50	48.38	55.25
48	48.50	50.38	58.75

Class 350

Size NPS	Sealing Element		Outer Ring
	Inside (B) Diameter	Outside (C) Diameter	Outside (D) Diameter
26	26.50	27.75	29.63
28	28.50	29.75	31.63
30	30.50	31.75	33.88
32	32.50	33.88	35.88
34	34.50	35.88	37.88
36	36.50	38.13	40.38
38	38.50	40.13	42.38
40	40.50	42.13	44.38
42	42.50	44.25	46.63
44	44.50	46.38	49.00
46	46.50	48.38	51.00
48	48.50	50.38	53.00
52	52.50	54.50	57.38
54	54.50	56.50	59.38
60	60.50	62.50	65.38
66	66.50	68.50	72.50
72	72.25	77.00	78.50
84	88.38	90.13	91.63
96	100.75	102.50	104.00

WARNING:

Properties/applications shown throughout this brochure are typical. Your specific application should not be undertaken without independent study and evaluation for suitability. For specific application recommendations consult Garlock. Failure to select the proper sealing products could result in property damage and/or serious personal injury.

Performance data published in this brochure has been developed from field testing, customer field reports and/or in-house testing.

While the utmost care has been used in compiling this brochure, we assume no responsibility for errors. Specifications subject to change without notice. This edition cancels all previous issues. Subject to change without notice.

Gasket Factors "M" and "Y"

"M" and "Y" data are to be used for flange designs only as specified in the ASME Boiler and Pressure Vessel Code Division 1, Section VIII, Appendix 2. They are not meant to be used as gasket seating stress values in actual service. Our bolt torque tables give that information and should be used as such.

"M" - Maintenance Factor

A factor that provides the additional preload needed in the flange fasteners to maintain the compressive load on a gasket after internal pressure is applied to a joint.







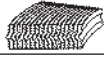

$$M = (W - A_2P) / A_1P$$

Where: W = Total Fastener force (lb. or N)
 A_2 = Inside area of gasket (in.² or mm²)
 P = Test pressure (psig or N/mm²)
 A_1 = Gasket area (in.² or mm²)

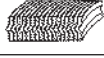
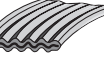
"Y" - Minimum Design Seating Stress

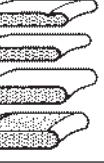
The minimum compressive stress in pounds per square inch (or bar) on the contact area of the gasket that is required to provide a seal at an internal pressure of 2 psig (0.14 bar).

$$Y = W / A_1$$

Gasket Design	Gasket Material	Gasket Factor "M"	Min. Design Seating Stress "Y" psi
Spiral wound metal, non-asbestos filled 	Stainless steel or MONEL®	3.00	10,000
Garlock CONTROLLED DENSITY® flexible graphite-filled spiral wound 	Stainless steel or MONEL®	3.00	7,500
Garlock EDGE® 	Stainless steel or MONEL®	2.00	5,000
Garlock GRAPHONIC® 	Stainless steel and flexible graphite Liquid service:	2.00 (1/16") 9.00 (1/8") 2.00	2,000 (1/16") 3,000 (1/8") 900
Corrugated metal, non-asbestos or Corrugated metal-jacketed, non-asbestos filled 	Soft aluminum Soft copper or brass Iron or soft steel MONEL® or 4%-6% chrome Stainless steel	2.50 2.75 3.00 3.25 3.50	2,900 3,700 4,500 5,500 6,500
Corrugated metal 	Soft aluminum Soft copper or brass Iron or soft steel MONEL® or 4%-6% chrome Stainless steel	2.75 3.00 3.25 3.50 3.75	3,700 4,500 5,500 6,500 7,600
Flat metal-jacketed, non-asbestos filled 	Soft aluminum Soft copper or brass Iron or soft steel MONEL® 4%-6% chrome Stainless steel	3.25 3.50 3.75 3.50 3.75 3.75	5,500 6,500 7,600 8,000 9,000 9,000
Grooved metal 	Soft aluminum Soft copper or brass Iron or soft steel MONEL® or 4%-6% chrome Stainless steel	3.25 3.50 3.75 3.75 4.25	5,500 6,500 7,600 9,000 10,100
Solid flat metal 	Soft aluminum Soft copper or brass Iron or soft steel MONEL® or 4%-6% chrome Stainless steel	4.00 4.75 5.50 6.00 6.50	8,800 13,000 18,000 21,800 26,000
Ring joint 	Iron or soft steel MONEL® or 4%-6% chrome Stainless steel	5.50 6.00 6.50	18,000 21,800 26,000

This table lists many commonly used gasket materials and contact facings with suggested design values of "M" and "Y" that generally have proven satisfactory in actual service when using effective gasket seating width B_1 described in the formula on page D-32. The design values and other details given in this table are suggested only and are not mandatory.

MONEL® is a registered trademark of International Nickel.

Torque Tables

These tables were developed to be used with Garlock spiral wound gaskets. They are to be used only as a general guide. They should not be considered to contain absolute values due to the large number of uncontrollable variables involved with bolted joints.

All bolt torque values are based upon the use of new nuts (ASTM A194, GR 2H) and new bolts (ASTM A193, GR B7) of proper design, acceptable quality and approved materials of construction as well as metallurgy. It is also required that two hardened steel washers be used under the head of each nut and that a thread lubricant (i.e. oil and graphite) be used on the nuts, bolts and washers.

The flanges are assumed to be in good condition and in compliance with ASME B16.5 specifications. Special attention should be given to seating surface finish and flatness.

Only torque wrenches that have been calibrated should be used. The proper bolt tightening pattern must be followed (see installation section on page D-42 for proper

bolting pattern) with the desired ultimate torque value arrived at in a minimum of three equal increments. All bolts in the flange should then be checked in consecutive bolt-to-bolt order.

The contact dimensions listed are taken from the ID and OD of the windings, which are different from the ASME ring gasket dimensions.

No provisions have been made in these tables to account for vibration effects on the bolts. These tables are based on ambient conditions, without compensation for elevated temperatures.

WARNING:

Properties/applications shown throughout this brochure are typical. Your specific application should not be undertaken without independent study and evaluation for suitability. For specific application recommendations consult Garlock. Failure to select the proper sealing products could result in property damage and/or serious personal injury.

Performance data published in this brochure has been developed from field testing, customer field reports and/or in-house testing.

While the utmost care has been used in compiling this brochure, we assume no responsibility for errors. Specifications subject to change without notice. This edition cancels all previous issues. Subject to change without notice.

Torque Tables

150# Raised Face Flanges

Nom. Pipe Size (inches)	No of Bolts	Size of Bolts	FLEXSEAL®		EDGE®		Kammprofile		GRAPHONIC®		Jacketed Gasket	
			Minimum Torque (ft.lbs)	Preferred Torque (ft.lbs)	Minimum Torque (ft.lbs)	Preferred Torque (ft.lbs)	Minimum Torque (ft.lbs)	Preferred Torque (ft.lbs)	Minimum Torque (ft.lbs)	Preferred Torque (ft.lbs)	Minimum Torque (ft.lbs)	Preferred Torque (ft.lbs)
0.50	4	0.50	16	47	9	52	8	42	11	37	18	53
0.75	4	0.50	22	60	12	60	11	54	16	60	25	60
1	4	0.50	30	60	15	60	13	60	21	60	27	60
1.25	4	0.50	33	60	16	60	24	60	33	60	42	60
1.5	4	0.50	47	60	23	60	31	60	43	60	59	60
2	4	0.63	74	120	36	120	55	120	87	120	94	120
2.5	4	0.63	87	120	43	120	63	120	101	120	108	120
3	4	0.63	120	120	63	120	102	120	120	120	120	120
4	8	0.63	92	120	47	120	76	120	105	120	111	120
5	8	0.75	124	200	63	200	106	200	146	200	189	200
6	8	0.75	178	200	89	200	137	200	185	200	173	200
8	8	0.75	200	200	128	200	190	200	250	200	200	200
10	12	0.88	236	320	120	320	178	320	235	320	300	320
12	12	0.88	320	320	163	320	178	320	312	320	320	320
14	12	1.00	408	490	209	490	268	490	396	490	451	490
16	16	1.00	421	490	210	490	267	490	377	490	449	490
18	16	1.13	649	710	328	710	381	710	560	710	562	710
20	20	1.13	572	710	289	710	335	710	494	710	562	710
24	20	1.25	820	1000	415	1000	438	1000	704	1000	740	1000

Based on ASTM A193 B7 bolts - 60,000 psi maximum bolt stress

300# Raised Face Flanges

Nom. Pipe Size (inches)	No of Bolts	Size of Bolts	FLEXSEAL®		EDGE®		Kammprofile		GRAPHONIC®		Jacketed Gasket	
			Minimum Torque (ft.lbs)	Preferred Torque (ft.lbs)	Minimum Torque (ft.lbs)	Preferred Torque (ft.lbs)	Minimum Torque (ft.lbs)	Preferred Torque (ft.lbs)	Minimum Torque (ft.lbs)	Preferred Torque (ft.lbs)	Minimum Torque (ft.lbs)	Preferred Torque (ft.lbs)
0.50	4	0.50	16	47	9	52	8	42	11	37	18	53
0.75	4	0.63	28	84	15	88	14	68	20	67	31	92
1	4	0.63	38	114	19	115	17	84	27	89	34	102
1.25	4	0.63	41	120	20	120	30	120	41	120	53	120
1.5	4	0.75	66	198	32	191	43	200	60	200	81	200
2	8	0.63	37	112	18	109	27	120	43	120	47	120
2.5	8	0.75	48	145	24	144	35	177	56	188	60	180
3	8	0.75	71	200	35	200	57	200	83	200	75	200
4	8	0.75	103	200	52	200	84	200	117	200	123	200
5	8	0.75	124	200	63	200	106	200	146	200	189	200
6	12	0.75	118	200	60	200	92	200	123	200	116	200
8	12	0.88	194	320	98	320	146	320	192	320	207	320
10	16	1.00	206	490	105	490	155	490	205	490	262	490
12	16	1.13	309	710	156	710	171	710	299	710	341	710
14	20	1.13	269	710	138	710	177	710	261	710	297	710
16	20	1.25	399	1000	203	1000	259	1000	365	1000	435	1000
18	24	1.25	478	1000	241	1000	280	1000	412	1000	414	1000
20	24	1.25	526	1000	266	1000	308	1000	454	1000	517	1000
24	24	1.50	723	1600	366	1600	386	1600	621	1600	652	1600

Based on ASTM A193 B7 bolts - 60,000 psi maximum bolt stress

Torque Tables

400# Raised Face Flanges

Nom. Pipe Size (inches)	No of Bolts	Size of Bolts	FLEXSEAL®		EDGE®		Kammprofile		GRAPHONIC®		Jacketed Gasket	
			Minimum Torque (ft.lbs)	Preferred Torque (ft.lbs)	Minimum Torque (ft.lbs)	Preferred Torque (ft.lbs)	Minimum Torque (ft.lbs)	Preferred Torque (ft.lbs)	Minimum Torque (ft.lbs)	Preferred Torque (ft.lbs)	Minimum Torque (ft.lbs)	Preferred Torque (ft.lbs)
0.50	4	0.50	16	47	17	52	8	42	Contact Engineering		18	53
0.75	4	0.63	28	84	29	88	14	68			31	92
1	4	0.63	38	114	38	115	17	84			34	102
1.25	4	0.63	41	120	40	120	30	120			53	120
1.5	4	0.75	66	198	64	191	43	200			81	200
2	8	0.63	37	112	36	109	27	120			47	120
2.5	8	0.75	48	145	48	144	35	177			60	180
3	8	0.75	71	200	71	200	57	200			75	200
4	8	0.88	149	320	120	320	97	320			142	320
5	8	0.88	190	320	146	320	123	320			218	320
6	12	0.88	173	320	138	320	106	320			133	320
8	12	1.00	280	490	22-	490	170	490			241	490
10	16	1.13	314	710	230	691	170	710			287	710
12	16	1.25	456	1000	345	1000	188	941			376	1000
14	20	1.25	373	1000	304	911	195	975			328	983
16	20	1.38	532	1630	445	1335	283	1360			475	1360
18	24	1.38	567	1360	527	1360	306	1360			452	1357
20	24	1.50	604	1600	563	1600	326	1600			547	1600
24	24	1.75	962	2887	975	2924	513	2566		868	2603	

Based on ASTM A193 B7 bolts - 60,000 psi maximum bolt stress

600# Raised Face Flanges

Nom. Pipe Size (inches)	No of Bolts	Size of Bolts	FLEXSEAL®		EDGE®		Kammprofile		GRAPHONIC®		Jacketed Gasket	
			Minimum Torque (ft.lbs)	Preferred Torque (ft.lbs)	Minimum Torque (ft.lbs)	Preferred Torque (ft.lbs)	Minimum Torque (ft.lbs)	Preferred Torque (ft.lbs)	Minimum Torque (ft.lbs)	Preferred Torque (ft.lbs)	Minimum Torque (ft.lbs)	Preferred Torque (ft.lbs)
0.50	4	0.50	16	47	17	52	8	42	Contact Engineering		18	53
0.75	4	0.63	28	84	29	88	14	68			31	92
1	4	0.63	38	114	38	115	17	84			34	102
1.25	4	0.63	41	120	40	120	30	120			53	120
1.5	4	0.75	66	198	64	191	43	200			81	200
2	8	0.63	37	112	36	109	27	120			47	120
2.5	8	0.75	48	145	48	144	35	177			60	180
3	8	0.75	71	200	71	200	57	200			75	200
4	8	0.88	149	320	120	320	97	320			142	320
5	8	1.00	221	490	170	490	143	490			254	490
6	12	1.00	202	490	160	480	123	490			155	466
8	12	1.13	307	710	241	710	187	710			264	710
10	16	1.25	346	1000	254	763	188	938			317	951
12	20	1.25	365	1000	276	829	151	753			301	904
14	20	1.38	408	1224	332	996	213	1066			358	1075
16	20	1.50	514	1543	430	1291	274	1370			460	1379
18	20	1.63	757	2200	704	2112	409	2044			604	1811
20	24	1.63	695	2085	647	1941	375	1875			629	1886
24	24	1.88	1103	3308	1117	3350	588	2940		994	2983	

Based on ASTM A193 B7 bolts - 60,000 psi maximum bolt stress

Torque Tables

900# Raised Face Flanges

Nom. Pipe Size (inches)	No of Bolts	Size of Bolts	FLEXSEAL®		EDGE®		Kammprofile		GRAPHONIC®		Jacketed Gasket	
			Minimum Torque (ft.lbs)	Preferred Torque (ft.lbs)	Minimum Torque (ft.lbs)	Preferred Torque (ft.lbs)	Minimum Torque (ft.lbs)	Preferred Torque (ft.lbs)	Minimum Torque (ft.lbs)	Preferred Torque (ft.lbs)	Minimum Torque (ft.lbs)	Preferred Torque (ft.lbs)
0.50	4	0.75	22	100	24	100	12	100	Contact Engineering		24	73
0.75	4	0.75	31	100	33	100	15	100			34	103
1	4	0.88	49	160	49	160	22	160			44	131
1.25	4	0.88	53	160	52	160	39	193			68	204
1.5	4	1.00	89	266	85	256	58	289			109	328
2	8	0.88	48	160	47	160	35	176			60	180
2.5	8	1.00	65	245	65	245	47	245			81	242
3	8	0.88	106	319	81	244	66	328			87	260
4	8	1.13	191	572	153	458	124	622			182	545
5	8	1.25	268	804	206	617	173	865			307	921
6	12	1.13	221	664	176	527	135	675			170	511
8	12	1.38	333	1000	303	909	225	1127			319	956
10	16	1.38	306	919	278	835	205	1026			347	1040
12	20	1.38	368	1103	302	907	165	824			329	988
14	20	1.50	388	1164	321	963	206	1031			347	1040
16	20	1.63	514	1541	495	1485	315	1575			529	1586
18	20	1.88	991	2972	933	2800	542	2710			800	2401
20	20	2.00	934	2802	984	2952	540	2850			956	2867
24	20	2.50	1382	4400	1582	4747	833	4400		1409	4227	

Based on ASTM A193 B7 bolts - 60,000 psi maximum bolt stress

1500# Raised Face Flanges

Nom. Pipe Size (inches)	No of Bolts	Size of Bolts	FLEXSEAL®		EDGE®		Kammprofile		GRAPHONIC®		Jacketed Gasket	
			Minimum Torque (ft.lbs)	Preferred Torque (ft.lbs)	Minimum Torque (ft.lbs)	Preferred Torque (ft.lbs)	Minimum Torque (ft.lbs)	Preferred Torque (ft.lbs)	Minimum Torque (ft.lbs)	Preferred Torque (ft.lbs)	Minimum Torque (ft.lbs)	Preferred Torque (ft.lbs)
0.50	4	0.75	22	100	24	100	20	100	Contact Engineering		24	73
0.75	4	0.75	31	100	33	100	25	100			34	103
1	4	0.88	49	160	49	160	36	160			44	131
1.25	4	0.88	80	240	52	160	64	193			68	204
1.5	4	1.00	118	353	85	256	96	289			109	328
2	8	0.88	76	227	47	160	59	176			60	180
2.5	8	1.00	108	325	65	245	79	245			81	242
3	8	1.13	150	451	104	355	140	419			111	332
4	8	1.25	231	694	169	506	229	686			200	601
5	8	1.50	323	970	218	800	305	915			325	975
6	12	1.38	289	867	212	680	272	815			206	617
8	12	1.63	432	1297	337	1100	418	1253			354	1063
10	12	1.88	754	2262	547	2000	673	2018			682	2045
12	16	2.00	647	2200	532	2200	484	2200			580	1741
14	16	2.25	684	3180	655	3180	701	3180			707	2121
16	16	2.50	1141	4400	969	4400	1027	4400			1035	3104
18	16	2.75	1606	5920	1513	5920	1464	5920			1297	3892
20	16	3.00	1921	7720	1810	7720	1748	7720			1758	5273
24	16	3.50	3100	13000	2867	13000	2516	13000		2553	7658	

Based on ASTM A193 B7 bolts - 60,000 psi maximum bolt stress

Torque Tables

2500# Raised Face Flanges

Nom. Pipe Size (inches)	No of Bolts	Size of Bolts	FLEXSEAL®		EDGE®		Kammprofile		GRAPHONIC®		Jacketed Gasket	
			Minimum Torque (ft.lbs)	Preferred Torque (ft.lbs)	Minimum Torque (ft.lbs)	Preferred Torque (ft.lbs)	Minimum Torque (ft.lbs)	Preferred Torque (ft.lbs)	Minimum Torque (ft.lbs)	Preferred Torque (ft.lbs)	Minimum Torque (ft.lbs)	Preferred Torque (ft.lbs)
0.50	4	0.75	22	100	24	100	20	100	Contact Engineering		24	73
0.75	4	0.75	31	100	33	100	25	100			34	103
1	4	0.88	49	160	49	160	36	160			44	131
1.25	4	1.00	93	279	60	245	75	245			79	237
1.5	4	1.13	129	387	94	355	106	355			120	360
2	8	1.00	88	264	55	245	68	245			70	210
2.5	8	1.13	119	357	71	355	87	355			89	266
3	8	1.25	166	500	115	500	154	500			122	367
4	8	1.50	245	800	178	800	242	800			212	636
5	8	1.75	430	1500	289	1500	406	1500			432	1297
6	8	2.00	611	2200	448	2200	574	2200			434	1303
8	12	2.00	548	2200	427	2200	529	2200			449	1347
10	12	2.50	831	4400	646	4400	794	4400			805	2415
12	12	2.75	1326	5920	963	5920	875	5920			1050	3150

Based on ASTM A193 B7 bolts - 60,000 psi maximum bolt stress

WARNING:

Properties/applications shown throughout this brochure are typical. Your specific application should not be undertaken without independent study and evaluation for suitability. For specific application recommendations consult Garlock. Failure to select the proper sealing products could result in property damage and/or serious personal injury.

Performance data published in this brochure has been developed from field testing, customer field reports and/or in-house testing.

While the utmost care has been used in compiling this brochure, we assume no responsibility for errors. Specifications subject to change without notice. This edition cancels all previous issues. Subject to change without notice.

Torque to Stress Bolts

The torque required to produce a certain stress in bolting is dependent on several conditions, including:

- Diameter and number of threads on bolt
- Condition of nut bearing surfaces
- Lubrication of bolt threads and nut bearing surfaces.

The tables below reflect the results of many tests to determine the relation between torque and bolt stress. Values are based on steel bolts that have been well-lubricated with a heavy graphite and oil mixture.

A non-lubricated bolt has an efficiency of about 50% of a well-lubricated bolt. Also, different lubricants produce results that vary from 50% to 100% of the tabulated stress figures.

For Alloy Steel Stud Bolts (Load in pounds on stud bolts when torque load is applied)

Nominal Diameter of Bolt (inches)	Number of Threads (per inch)	Diameter at Root of Thread (inches)	Area at Root of Thread (sq. inch)	Stress					
				30,000 psi		45,000 psi		60,000 psi	
				Torque (ft lbs)	Compression (lbs)	Torque (ft lbs)	Compression (lbs)	Torque (ft lbs)	Compression (lbs)
1/4	20	0.185	0.027	4	810	6	1,215	8	1,620
5/16	18	0.240	0.045	8	1,350	12	2,025	16	2,700
3/8	16	0.294	0.068	12	2,040	18	3,060	24	4,080
7/16	14	0.345	0.093	20	2,790	30	4,185	40	5,580
1/2	13	0.400	0.126	30	3,780	45	5,670	60	7,560
9/16	12	0.454	0.162	45	4,860	68	7,290	90	9,720
5/8	11	0.507	0.202	60	6,060	90	9,090	120	12,120
3/4	10	0.620	0.302	100	9,060	150	13,590	200	18,120
7/8	9	0.731	0.419	160	12,570	240	18,855	320	25,140
1	8	0.838	0.551	245	16,530	368	24,795	490	33,060
1-1/8	8	0.963	0.728	355	21,840	533	32,760	710	43,680
1-1/4	8	1.088	0.929	500	27,870	750	41,805	1,000	55,740
1-3/8	8	1.213	1.155	680	34,650	1,020	51,975	1,360	69,300
1-1/2	8	1.338	1.405	800	42,150	1,200	63,225	1,600	84,300
1-5/8	8	1.463	1.680	1,100	50,400	1,650	75,600	2,200	100,800
1-3/4	8	1.588	1.980	1,500	59,400	2,250	89,100	3,000	118,800
1-7/8	8	1.713	2.304	2,000	69,120	3,000	103,680	4,000	138,240
2	8	1.838	2.652	2,200	79,560	3,300	119,340	4,400	159,120
2-1/4	8	2.088	3.423	3,180	102,690	4,770	154,035	6,360	205,380
2-1/2	8	2.338	4.292	4,400	128,760	6,600	193,140	8,800	257,520
2-3/4	8	2.588	5.259	5,920	157,770	8,880	236,655	11,840	315,540
3	8	2.838	6.324	7,720	189,720	11,580	264,580	15,440	379,440

For Machine Bolts and Cold Rolled Steel Stud Bolts (Load in pounds on stud bolts when torque load is applied)

Nominal Diameter of Bolt (inches)	Number of Threads (per inch)	Diameter at Root of Thread (inches)	Area at Root of Thread (sq. inch)	Stress					
				7,500 psi		15,000 psi		30,000 psi	
				Torque (ft lbs)	Compression (lbs)	Torque (ft lbs)	Compression (lbs)	Torque (ft lbs)	Compression (lbs)
1/4	20	0.185	0.027	1	203	2	405	4	810
5/16	18	0.240	0.045	2	338	4	675	8	1,350
3/8	16	0.294	0.068	3	510	6	1,020	12	2,040
7/16	14	0.345	0.093	5	698	10	1,395	20	2,790
1/2	13	0.400	0.126	8	945	15	1,890	30	3,780
9/16	12	0.454	0.162	12	1,215	23	2,340	45	4,860
5/8	11	0.507	0.202	15	1,515	30	3,030	60	6,060
3/4	10	0.620	0.302	25	2,265	50	4,530	100	9,060
7/8	9	0.731	0.419	40	3,143	80	6,285	160	12,570
1	8	0.838	0.551	62	4,133	123	8,265	245	16,530
1-1/8	7	0.939	0.693	98	5,190	195	10,380	390	20,760
1-1/4	7	1.064	0.890	137	6,675	273	13,350	545	26,700
1-3/8	6	1.158	1.054	183	7,905	365	15,810	730	31,620
1-1/2	6	1.283	1.294	219	9,705	437	19,410	875	38,820
1-5/8	5-1/2	1.389	1.515	300	11,363	600	22,725	1,200	45,450
1-3/4	5	1.490	1.744	390	13,080	775	26,160	1,550	52,320
1-7/8	5	1.615	2.049	525	15,368	1,050	30,735	2,100	61,470
2	4-1/2	1.711	2.300	563	17,250	1,125	34,500	2,250	69,000

Flange and Bolt Dimensions

For Standard Flanges

NPS (inches)	150 psi				300 psi				400 psi				600 psi			
	Dia. of Flange (inches)	No. of Bolts	Dia. of Bolts (Inches)	Bolt Circle (Inches)	Dia. of Flange (Inches)	No. of Bolts	Dia. of Bolts (Inches)	Bolt Circle (Inches)	Dia. of Flange (Inches)	No. of Bolts	Dia. of Bolts (Inches)	Bolt Circle (Inches)	Dia. of Flange (Inches)	No. of Bolts	Dia. of Bolts (Inches)	Bolt Circle (Inches)
1/4	3-3/8	4	1/2	2-1/4	3-3/8	4	1/2	2-1/4	3-3/8	4	1/2	2-1/4	3-3/8	4	1/2	2-1/4
1/2	3-1/2	4	1/2	2-3/8	3-3/4	4	1/2	2-5/8	3-3/4	4	1/2	2-5/8	3-3/4	4	1/2	2-5/8
3/4	3-7/8	4	1/2	2-3/4	4-5/8	4	5/8	3-1/4	4-5/8	4	5/8	3-1/4	4-5/8	4	5/8	3-1/4
1	4-1/4	4	1/2	3-1/8	4-7/8	4	5/8	3-1/2	4-7/8	4	5/8	3-1/2	4-7/8	4	5/8	3-1/2
1-1/4	4-5/8	4	1/2	3-1/2	5-1/4	4	5/8	3-7/8	5-1/4	4	5/8	3-7/8	5-1/4	4	5/8	3-7/8
1-1/2	5	4	1/2	3-7/8	6-1/8	4	3/4	4-1/2	6-1/8	4	3/4	4-1/2	6-1/8	4	3/4	4-1/2
2	6	4	5/8	4-3/4	6-1/2	8	5/8	5	6-1/2	8	5/8	5	6-1/2	8	5/8	5
2-1/2	7	4	5/8	5-1/2	7-1/2	8	3/4	5-7/8	7-1/2	8	3/4	5-7/8	7-1/2	8	3/4	5-7/8
3	7-1/2	4	5/8	6	8-1/4	8	3/4	6-5/8	8-1/4	8	3/4	6-5/8	8-1/4	8	3/4	6-5/8
3-1/2	8-1/2	8	5/8	7	9	8	3/4	7-1/4	9	8	7/8	7-1/4	9	8	7/8	7-1/4
4	9	8	5/8	7-1/2	10	8	3/4	7-7/8	10	8	7/8	7-7/8	10-3/4	8	7/8	8-1/2
5	10	8	3/4	8-1/2	11	8	3/4	9-1/4	11	8	7/8	9-1/4	13	8	1	10-1/2
6	11	8	3/4	9-1/2	12-1/2	12	3/4	10-5/8	12-1/2	12	7/8	10-5/8	14	12	1	11-1/2
8	13-1/2	8	3/4	11-3/4	15	12	7/8	13	15	12	1	13	16-1/2	12	1-1/8	13-3/4
10	16	12	7/8	14-1/4	17-1/2	16	1	15-1/4	17-1/2	16	1-1/8	15-1/4	20	16	1-1/4	17
12	19	12	7/8	17	20-1/2	16	1-1/8	17-3/4	20-1/2	16	1-1/4	17-3/4	22	20	1-1/4	19-1/4
14	21	12	1	18-3/4	23	20	1-1/8	20-1/4	23	20	1-1/4	20-1/4	23-3/4	20	1-3/8	20-3/4
16	23-1/2	16	1	21-1/4	25-1/2	20	1-1/4	22-1/2	25-1/2	20	1-3/8	22-1/2	27	20	1-1/2	23-3/4
18	25	16	1-1/8	22-3/4	28	24	1-1/4	24-3/4	28	24	1-3/8	24-3/4	29-1/4	20	1-5/8	25-3/4
20	27-1/2	20	1-1/8	25	30-1/2	24	1-1/4	27	30-1/2	24	1-1/2	27	32	24	1-5/8	28-1/2
24	32	20	1-1/4	29-1/2	36	24	1-1/2	32	36	24	1-3/4	32	37	24	1-7/8	33

NPS (inches)	900 psi				1500 psi				2500 psi			
	Dia. of Flange (inches)	No. of Bolts	Dia. of Bolts (Inches)	Bolt Circle (Inches)	Dia. of Flange (Inches)	No. of Bolts	Dia. of Bolts (Inches)	Bolt Circle (Inches)	Dia. of Flange (Inches)	No. of Bolts	Dia. of Bolts (Inches)	Bolt Circle (Inches)
1/2	4-3/4	4	3/4	3-1/4	4-3/4	4	3/4	3-1/4	5-1/4	4	3/4	3-1/2
3/4	5-1/8	4	3/4	3-1/2	5-1/8	4	3/4	3-1/2	5-1/2	4	3/4	3-3/4
1	5-7/8	4	7/8	4	5-7/8	4	7/8	4	6-1/4	4	7/8	4-1/4
1-1/4	6-1/4	4	7/8	4-3/8	6-1/4	4	7/8	4-3/8	7-1/4	4	1	5-1/8
1-1/2	7	4	1	4-7/8	7	4	1	4-7/8	8	4	1-1/8	5-3/4
2	8-1/2	8	7/8	6-1/2	8-1/2	8	7/8	6-1/2	9-1/4	8	1	6-3/4
2-1/2	9-5/8	8	1	7-1/2	9-5/8	8	1	7-1/2	10-1/2	8	1-1/8	7-3/4
3	9-1/2	8	7/8	7-1/2	10-1/2	8	1-1/8	8	12	8	1-1/4	9
4	11-1/2	8	1-1/8	9-1/4	12-1/4	8	1-1/4	9-1/2	14	8	1-1/2	10-3/4
5	13-3/4	8	1-1/4	11	14-3/4	8	1-1/2	11-1/2	16-1/2	8	1-3/4	12-3/4
6	15	12	1-1/8	12-1/2	15-1/2	12	1-3/8	12-1/2	19	8	2	14-1/2
8	18-1/2	12	1-3/8	15-1/2	19	12	1-5/8	15-1/2	21-3/4	12	2	17-1/4
10	21-1/2	16	1-3/8	18-1/2	23	12	1-7/8	19	26-1/2	12	2-1/2	21-1/4
12	24	20	1-3/8	21	26-1/2	16	2	22-1/2	30	12	2-3/4	24-3/8
14	25-1/4	20	1-1/2	22	29-1/2	16	2-1/4	25				
16	27-3/4	20	1-5/8	24-1/2	32-1/2	16	2-1/2	27-3/4				
18	31	20	1-7/8	27	36	16	2-3/4	30-1/2				
20	33-3/4	20	2	29-1/2	38-3/4	16	3	32-3/4				
24	41	20	2-1/2	35-1/2	46	16	3-1/2	39				

WARNING:

Properties/applications shown throughout this brochure are typical. Your specific application should not be undertaken without independent study and evaluation for suitability. For specific application recommendations consult Garlock. Failure to select the proper sealing products could result in property damage and/or serious personal injury.

Performance data published in this brochure has been developed from field testing, customer field reports and/or in-house testing.

While the utmost care has been used in compiling this brochure, we assume no responsibility for errors. Specifications subject to change without notice. This edition cancels all previous issues. Subject to change without notice.

Gasket Installation

In a flanged connection, all components must be correct to achieve a seal. The most common cause of leaky gasketed joints is improper installation procedures.

Bolting Procedures

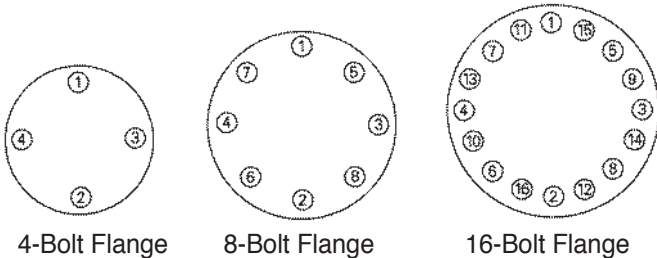

- Place the gasket on the flange surface to be sealed.
- Bring the opposing flange into contact with the gasket.
- Bolts must be new or in as-new condition. Clean the threads and lubricate them with a quality lubricant, such as an oil and graphite mixture.
- Place the bolts into the bolt holes.
- Finger-tighten the nuts.
- Follow the bolting sequence in the diagrams above.
- During the initial tightening sequence, do not tighten any bolts more than 30% of the recommended bolt stress. Doing so will cause cocking of the flange and the gasket will be crushed.
- Upon reaching the recommended torque requirements, do a circular bolt-to-bolt torque check to make certain that the bolts have been stressed evenly.
- Due to creep and stress relaxation, it is essential to prestress the bolts to ensure adequate stress load during operation.

Prestressing Bolts for Thermal Expansion

Bolts should be prestressed to compensate for thermal expansion as well as for relaxation, creep, hydrostatic end pressure and residual gasket loads.

A difference in the coefficient of thermal expansion between the materials of the flange and the bolts may change loads. In cases of serious thermal expansion, it may be necessary to apply a minimum of stress to the bolts and allow the pipe expansion to complete the compression of the gasket.

A gasket with a centering guide ring should be compressed to the guide ring. A gasket without a centering guide ring must be installed with precautions taken to prevent thermal expansion from crushing the gasket beyond its elastic limit.

WARNING:

Properties/applications shown throughout this brochure are typical. Your specific application should not be undertaken without independent study and evaluation for suitability. For specific application recommendations consult Garlock. Failure to select the proper sealing products could result in property damage and/or serious personal injury.

Performance data published in this brochure has been developed from field testing, customer field reports and/or in-house testing.

While the utmost care has been used in compiling this brochure, we assume no responsibility for errors. Specifications subject to change without notice. This edition cancels all previous issues. Subject to change without notice.

Troubleshooting Leaking Joints

One of the best methods for determining the cause of joint leakage is the careful examination of the gasket where the leakage occurred.

Observation	Possible Remedies
Gasket badly corroded	<ul style="list-style-type: none"> • Select replacement material with improved corrosion resistance.
Gasket extruded excessively	<ul style="list-style-type: none"> • Select replacement material with better cold flow properties. • Select replacement material with better load capacity—i.e., more dense.
Gasket grossly crushed	<ul style="list-style-type: none"> • Select replacement material with better load carrying capacity. • Provide means to prevent crushing the gasket by use of a stop ring or redesign of flanges.
Gasket mechanically damaged due to overhang of raised face or flange bore.	<ul style="list-style-type: none"> • Review gasket dimensions to insure gaskets are proper size. • Make certain gaskets are properly centered in joint.
No apparent gasket compression achieved	<ul style="list-style-type: none"> • Select softer gasket material. • Select thicker gasket material. • Reduce gasket area to allow higher unit seating load.
Gasket substantially thinner on OD than ID due to excessive flange rotation or bending	<ul style="list-style-type: none"> • Alter gasket dimensions to move gasket reaction closer to bolts to minimize bending movement. • Provide stiffness to flange by means of back-up rings. • Select softer gasket material to lower required seating stresses. • Reduce gasket area to lower seating stresses.
Gasket unevenly compressed around circumference	<ul style="list-style-type: none"> • Make certain proper sequential bolt-up procedures are followed. • Ensure flanges are properly aligned
Gasket thickness varies periodically around circumference	<ul style="list-style-type: none"> • Provide reinforcing rings for flanges to better distribute bolt load. • Select gasket material with lower seating stress. • Provide additional bolts if possible to obtain better load distribution. • If flanges are warped, remachine or use softer gasket material.

Ordering Guide

RW, RWI Spiral Wound

When ordering, specify:

- Nominal pipe size or gasket dimensions, and pressure class
- Winding and filler materials
- Centering and/or inner compression ring material

SW Spiral Wound

When ordering, specify:

- OD and ID dimensions (and tolerance, if other than standard—see page D-19)
- Thickness of gasket
- Winding and filler material
- Inner ring material, if required (Style SWI)
- Pressure rating

HH, MC and MCR Manhole

When ordering, specify:

- Make and model of boiler and/or equipment if available (See chart page D-10)
- Gasket style and configuration
- Dimensions of gasket (thickness, flange seating width, and shape)
- Maximum operating pressure and temperature
- Type of metal and filler materials

Custom Gaskets

A spiral wound gasket can be made to almost any dimension required. Possible designs include multiple windings and rings, with combinations of different fillers or special winding materials and ring shapes. Describe your application or send us a drawing and we'll help you design the appropriate winding.

WARNING:

Properties/applications shown throughout this brochure are typical. Your specific application should not be undertaken without independent study and evaluation for suitability. For specific application recommendations consult Garlock. Failure to select the proper sealing products could result in property damage and/or serious personal injury.

Performance data published in this brochure has been developed from field testing, customer field reports and/or in-house testing.

While the utmost care has been used in compiling this brochure, we assume no responsibility for errors. Specifications subject to change without notice. This edition cancels all previous issues. Subject to change without notice.

Heat Exchanger

The size restrictions for heat exchanger gaskets depend only on the available sizes of the materials. Heat exchanger gaskets are commonly made in diameters up to 120", with rib widths up to 1-1/4" and thicknesses up to 1/4".

When ordering, specify:

- Style number
- Shape (Give configuration code, page D-13)
- Thickness
- Material (metal or metal and filler)

Plus specify (according to diagram below):

1. Outside diameter
2. Inside diameter
3. Rib width
4. Radii on ribs, at rib intersect points and around bolt holes
5. Bolt circle diameter
6. Distance from center line of gasket to center line of ribs
7. Size and number of bolt holes

Note: In addition to the above information, drawings of your application are always helpful in proper dimensioning of gaskets.

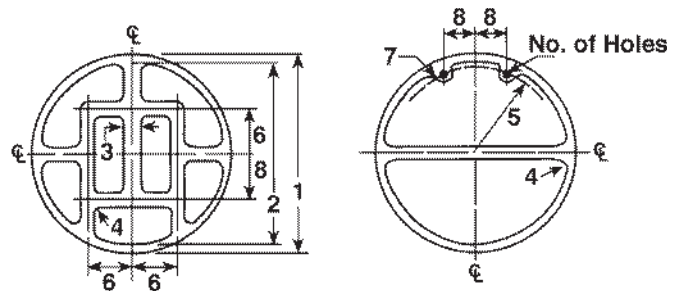

Application Data Form

Date _____

From _____

For: Garlock Metallic Gasketing Engineering

Title _____

Fax 1-281-458-0502

Company _____

Page: 1 of _____

Address _____

Drawing attached Yes No

Fax No. _____

Phone No. _____

E-mail Address _____

Application

Pipe Flange

Pumps – centrifugal / horizontal split case

Heat Exchanger

Flue Duct

Manway

Valve Bonnet

Compressor

Other _____

Service Conditions

Maximum Temperature _____ °F/°C

Continuous Operating Temperature _____ °F/°C

Internal Pressure _____ psig / bar

PSIG / bar Continuous Intermittent

Thermal Cycling _____ / 24 hours

Vibration Yes No

Other (specify) _____

Bolts

Grade _____

Diameter _____

Length _____

Number _____

Chemical Compatibility

Media _____

pH _____

Concentration _____

Liquid or Gas _____

Flange

Standard

Material _____

Size _____ Rating _____

Surface Finish _____ RMS

Phonographic Concentric

Face (raised, flat, tongue & groove, etc.) _____

Non-Standard

Material _____

I.D. / O.D. _____

Flange Thickness _____

Bolt Circle Diameter _____

Surface Finish _____ RMS

Phonographic Concentric

Face (raised, flat, tongue & groove, etc.) _____

Comments: _____

Common Abbreviations

SI - International Metric Standard	N - Newton
Pa - Pascal	in - inch
psi - pounds per square inch	ft - foot
psig - pounds per square inch gage	yd - yard
oz - ounce	m - meter
g - gram	gal - gallon
lbf - pound force	l - liter
kgf - kilogram force	

Prefixes

M (mega)	= 1,000,000	= 10 ⁶
k (kilo)	= 1,000	= 10 ³
c (centi)	= 0.01	= 10 ⁻²
m (milli)	= 0.001	= 10 ⁻³
u (micro)	= 0.000001	= 10 ⁻⁶

Metric Conversions

To Convert from:	To SI Units:	Multiply by:
Length		
mil	mm	0.0254
in	mm	25.4
in	cm	2.54
ft	m	0.3048
yd	m	0.9144
Weight		
oz	g	28.35
oz	kg	0.0283
lb	g	453.6
lb	kg	0.4536
lb	N	4.4482
Force		
lbf	N	4.448
kgf	N	9.8066
Area		
in ²	cm ²	6.4516
ft ²	m ²	0.0929
Pressure		
bar	psi	14.5
psi	Pa	6895
psi	kPa	6.89
psi	bar	0.069
psi	MPa	0.0069
N/m ²	Pa	1.00
N/mm ²	MPa	1.00
Torque		
in-lb	Nm	0.113
ft-lb	Nm	1.3558
Density		
oz/in ³	g/cm ³	1.73
g/cm ³	kg/m ³	1000
lb/ft ³	kg/m ³	16.02
lb/ft ³	g/cm ³	0.01602
Adhesion		
lb/in	kN/m	0.1751
Volume		
gal	l	3.7854
gal	m ³	0.0038

More than just great products...

Beyond offering you the widest available range of products for packing and sealing, Garlock enhances the value of its products with technical services and comprehensive training programs:

- ISO 9001:2000 registration for Industrial Gasketing, Industrial Packing, KLOZURE® Oil Seals, Bearing Protectors, and Mechanical Seals, Expansion Joints, Hydraulic Components, and Industrial Rubber Products.
- A global network of stocking Authorized Garlock Distributors.
- Factory sales representatives and applications engineers available for problem solving when and where it is needed.
- Toll-free 800 telephone and fax numbers for immediate product information.
- In-plant surveys of equipment and processes, providing the customer with recommendations to identify and eliminate sealing and packing problems before they start.
- The most sophisticated and most comprehensive test facilities available.
- Technical field seminars on all Garlock products.
- Factory-sponsored product training programs, including hands-on seminars, to ensure that Garlock representatives and their distributor personnel are the best in the industry.
- Technical Bulletins to keep you up-to-date on product enhancements and changes.

Customers who specify Garlock fluid sealing products get, at no extra cost, the high quality support needed to run a profitable operation.

AUTHORIZED REPRESENTATIVE

Garlock
SEALING TECHNOLOGIES®

an EnPro Industries company

Garlock Sealing Technologies
1666 Division Street
Palmyra, New York 14522 USA
+1.315.597.4811
Toll Free 1.800.448.6688
Toll Free Fax: 1.800.543.0598
+1.315.597.3039

www.garlock.com



WARNING:

Properties/applications shown throughout this brochure are typical. Your specific application should not be undertaken without independent study and evaluation for suitability. For specific application recommendations consult Garlock. Failure to select the proper sealing products could result in property damage and/or serious personal injury.

Performance data published in this brochure has been developed from field testing, customer field reports and/or in-house testing.

While the utmost care has been used in compiling this brochure, we assume no responsibility for errors. Specifications subject to change without notice. This edition cancels all previous issues. Subject to change without notice.

GARLOCK is a registered trademark for packings, seals, gaskets, and other products of Garlock.

© Garlock Inc 2010. All rights reserved worldwide.

Other Garlock facilities are located in:

Columbia, SC, USA	Phone +1.803.783.1880	Fax +1.803.783.4279
Houston, TX, USA	Phone +1.281.840.4800	Fax +1.281.840.4756
Sydney, Australia	Phone +61.2.9793.2511	Fax +61.2.9793.2544
São Paulo, Brazil	Phone +55.11.4352.6161	Fax +55.11.4352.8181
Sherbrooke, Canada	Phone +1.819.563.8080	Fax +1.819.563.5620
W. Yorkshire, England	Phone +44.1422.313600	Fax +44.1422.313601
Saint-Étienne, France	Phone +33.4.7743.5100	Fax +33.4.7743.5151
Neuss, Germany	Phone +49.2131.3490	Fax +49.2131.349.222
Mexico City, Mexico	Phone +52.55.50.78.46.00	Fax +52.555.368.0418
Singapore	Phone +65.6285.9322	Fax +65.6284.5843
Shanghai, China	Phone +86.021.62789702	Fax +86.021.62787826
Dubai, UAE	Phone +971.4.8833652	Fax +971.4.8833682
Pune, India	Phone +91.20.3061.6608	Fax +91.20.3061.6699